

SJVN LIMITED



NATHPA JHAKRI HYDRO POWER STATION

TENDER DOCUMENTS FOR CONSTRUCTION OF BUILDINGS AND ROADS

VOLUME-I

**NOTICE INVITING TENDER
INFORMATION AND INSTRUCTIONS FOR TENDERERS
PERCENTAGE RATE TENDER FOR WORKS AND MEMORANDUM
GENERAL CONDITIONS OF CONTRACT
FORMS FOR DEEDS OF GUARANTEES AND HYPOTHECATION
SPECIAL CONDITIONS OF CONTRACT
ANNEXURES**

SJVN LIMITED

(A joint Venture of Govt. of India & Govt. H. P.)

(Nathpa Jhakri Hydro Power Station)

PERCENTAGE RATE TENDER

FOR

PACKAGE NO./TENDER NO. PCD-2961(CIVIL)/2026

**Name of work: “Painting Work on Ventilation Ducts of NJHPS Power House Complex”
PCD-2961(Civil)/2026.**

To be submitted by 13.00 hours on 25/03/2026 through e-tendering. Tender shall be opened in presence of tenders who may be present at 14.00 hours on 25/03/2026 in the office of the HOD (P&C) NJHPS, SJVN Ltd., Jhakri.

Contractor

For & on behalf of SJVN Ltd.



SJVN Limited

(A Joint venture of Govt. of India and Govt. of H.P)

Navratna CPSE

CIN: L40101HP1988GOI008409

PRESS NOTICE

E- Tender No. PCD-2961(civil)/2026

Online bids (e-tender) on Domestic Competitive Bidding (DCB) are invited on behalf of SJVN Ltd. for **“Painting Work on Ventilation Ducts of NJHPS Power House Complex” PCD-2961(Civil)/2026.”**

Last date for downloading of bid document is 24/03/2026 (12:00 Hrs.)

Last date for bid submission is 25/03/2026 (13:00 Hrs.).

For details & all future Amendments/Corrigendum to the NIT please visit websites <https://etender.sjvn.co.in>, www.sjvn.nic.in, and www.eprocure.gov.in.

All other terms and conditions will remain unchanged.

For and on behalf of SJVN Ltd.

विभागाध्यक्ष
प्रापण एवं संविदा विभाग,
एनजेएचपीएस, एसजेवीएन लि० ,
झाकडी-172201

Contractor

For & on behalf of SJVN Ltd.

**Tender documents
Volume - I**

Contents	Page
Section-I Information And instructions For Tender	I-1 To 1-4
Section-II Item Rate Tender or Percentage Rate Tender For Works And Memorandum	II-1 To II-2
Section-III General Conditions Of Contract	III-1 To III-30
Definitions	III-1
Clauses	
1. Security Deposit	III-2
2. Commencement of Work	III-2 To 3
3. Determination Of Contract	III-3 To 4
4. Default By Contractor	III-4 To 5
5. Extension Of Time	III-5
6. Completion Certificate	III-5 To 6
7. Payment On Account	III-6
8. Submission Of Bills	III-6
8A. Measurements	III-6 To 7
9. Bills On Printed Forms	III-7
9A. Payments Through Bank	III-7
10. Stores Supplied By SJVN (NJHPS)	III-7 To 8
10A. Removal Of Materials From Premises	III-8
10B. Payment Against Materials	III-8
10C. Price Variations	III-8 To 11
10D. Materials Obtained From Excavation Etc.	III-11
11. Work To Specifications	III-11
12. Deviations	III-11 To 13
12A. Deviations Bases On Analysis of Rates And Other Factors	III-13 To 14
13. Closure Of Contract In Full Or Part Due To Reduction In Scope of Work	III-14
14. Work To The Satisfaction Of Engineer-In-Charge	III-14
15. Work To Be Open To Inspection	III-14 To 15
16. Convening Of Work	III-15
17. Liability For Damage Defects Or Imperfections And Rectifications Thereof	III-15
18. Construction Material, Plant And Equipment	III-15 To 16

Contractor

For & on behalf of SJVN Ltd.

18A.	Compensation to Contractors Workmen	III-16
19.	Labour	III-16
19(a to f).	Payment Of Wages To Labour	III-16
19A.	Female Labourers	III-17
19B.	Safety Provision Facilities	III-17
19C.	Regarding Strength of Labour	III-17
19D.	Compliance Of SJVN Rules	III-17
19E.	Leave And Pay Rules	III-17 To 19
19F.	Breach Of SJVN Labour Regulation By The Contractor	III-19 To 20
19G.	Specification of Labour Huts	III-20 To 21
19H.	Removal Of Contractor's Men	III-21
20.	Contractor To Comply With Minimum Wages Act.	III-21
21.	Assigning And Subletting	III-21 To 22
22.	Sum Payable By Way Of Compensation To Be Considered As Reasonable.	III-22
23.	Changes In Constitution	III-22
24.	Inspection And Approval	III-22
25.	Arbitration	III-22 To 23
26.	Patent Rights	III-23
27.	Payments For Lump Sum Items	III-23
28.	Work Where No Specifications	III-23
29.	Over Payments And Under Payments	III-23 to 24
30.	Labour From Controlled Areas	III-24 To 25
31.	Water Charges	III-25& 31A.
31B.	Electricity Charges	III-25
32.	Alternative To Piped Water Supply	III-25 To 26
33.	Economical Use of Materials Procured With the Assistance Of SJVN	III-26
34.	Return Of Plant And Machinery By The Contractor	III-26
35.	Asphaltic Work	III-26
36.	Technical Staff Of The Contractor	III-26 To 27
37.	Taxes	III-27
38.	Recovery From Contractors	III-27
39.	Termination Of Contract On Death	III-27
40.	Contractor's Near Relatives Employed In SJVN	III-27
41.	Retired Govt. Servants Taking Up Contract	III-27
42.	Return Of Unused Material	III-27 To 28
43.	Advances	III-28 To 29
44.	Schedule of Materials	III-30
Section-IV	Forms For Deeds Of Guarantees And Hypothecation Appendix-I : Form For Bank	

Contractor

For & on behalf of SJVN Ltd.

	Guarantee For Mobilization Advance	IV-1
	Appendix-II : Form For Hypothecation Deed For Machinery Advance.	IV-2 To 4
	Appendix-III : Form For Insurance Of Machinery/Equipment	IV-5
	Appendix-IV : Performa Bank Guarantee In Lieu Of Earnest Money	IV-6 To 7
	Appendix-V : Performa Bank Guarantee In Lieu Of Security Deposit	IV-8 To 10
Section-V	Special Conditions Of Contract	V-1 To 7
Section-VI	Annexures	
	Annexure-A : Safety Code.	VI-1 To 4
	Annexure-B : Model Rules For The Protection Of Health And Sanitary Arrangement For Workers Employed By SJVN Or Its Contractors	VI-5 To 7
	Annexure-C : SJVN Contractors Labour Regulations.	VI-8 To 18
	Responsibilities under Contract-Labour, Act-1970	VI-19 To 24
Section-VII	Schedule of Qty. in Original	VII-1 To



एसजेवीएन लिमिटेड SJVN Ltd.
(भारत सरकार तथा हिमाचल प्रदेश सरकार का सांझा उपक्रम)
(Navratna CPSE)
(6X250MW नाथपा झाकड़ी जल विद्युत स्टेशन)
प्रापण एवं संविदा विभाग, झाकड़ी, जिला शिमला, हि° प्र°-. 172201
फोन. 01782-275236 <http://www.sjvn.nic.in>
जी एस टी संख्या (GST No.) 02AAICS1307F1ZY
सिन् संख्या (CIN No.) L40101HP1988GOI008409

NOTICE INVITING TENDERS

Open **e-tenders** under two bid system are hereby invited on behalf of SJVN Limited from appropriate class of registered / eligible contractors (**Except JV/ Consortium**) for road, building and other civil works enlisted with HPPWD / CPWD / HPSEB / Public Undertakings / any other Govt./ Semi Govt. Organization for the following work: -

Tender No.	Name of Work.	Estimated Cost. (In Rs.)	Tender Documents cost (In Rs.)	EMD (In Rs.)	Date of availability/ downloading of bid document.	Last date of submission/ uploading of bids.	Date of opening of bid	Completion Time
PCD-2961	Painting Work on Ventilation Ducts of NJHPS Power House Complex	40,93,072 (without GST)	3540/- (Rs.3,000 /- + GST @18% i.e. Rs. 540/-)	81861	03/03/2026 (20:00 Hrs.) to 24/03/2026 (12:00 Hrs)	25/03/2026 (13:00 Hrs)	25/03/2026 (14:00 Hrs)	05 months

Note :-

- (i) The detailed NIT, Tender document, IFB, Schedule-1 (General Information & Bank Account Detail) & Schedule-2 and Annexures shall be available at <https://etender.sjvn.co.in>, www.sjvn.nic.in & www.eprocure.gov.in w.e.f. **03.03.2026 (20:00 Hrs.)**
- (ii) The bids are to be submitted electronically through e-tendering at <https://etender.sjvn.co.in>
- (iii) The corrigendum's and amendments if any shall be uploaded on <https://etender.sjvn.co.in> and above websites; therefore, all bidders requested to frequently visit the web sites till the schedule date of submission of bid.

Contractor

For & on behalf of SJVN Ltd.

TERMS AND CONDITIONS :

1. BID SUBMISSION :

(A) The tender shall be comprises of two parts in the following manner :

(a) **Techno-Commercial Bid:**

Part-I – Techno-Commercial Bid comprises of the following:-

1. EMD/Bid Security
2. Cost of tender Document
3. Registration certificate as contractor (**Except JV/ Consortium**) for road, building and other civil works enlisted with HPPWD / CPWD / HPSEB / Public Undertakings / any other Govt./ Semi Govt. Organization
4. GST No., PAN
5. EPF Code No.
6. Schedule -1 & Schedule- 2
7. Documents as per Qualification requirements as per Cluause-5 below
8. Bid security Declaration as per Annexure - B,
9. Undertaking as per Annexure-D along with Annexure-II (Guidelines on Banning of Business Dealings),
10. Undertaking of Self certification regarding Local content as per Annexure-E
11. Undertaking as per Annexure - G
12. Undertaking as per Annexure- H

(I) The bid documents shall be uploaded electronically and submitted online along with scanned copies of all the requisite documents. Some of the documents viz. Bid Security (if in the form of FDR/TDR), Power of Attorney, etc. are required to be submitted in physical form also.

(II) The time limit for submission of documents required in physical form shall be ten (10) days after the deadline for submission of e-bids in respect of following documents:-

- (i) **EMD (If not received online)**
- (ii) **Power of Attorney (if applicable)**
- (iii) **Any other documents required to be submitted in physical form in addition to above as per the requirement of particular tender.**

(III) The original documents in physical form submitted after the period as specified above shall not be entertained and such bids shall be treated as late bids. If the original documents in physical forms are found to be at variance than the scanned copies submitted earlier along with e-bids, the bids will be treated as non-responsive.

(b) **Price bid :**

Part-II- Price bid

(B) The above dynamic schedule is to be filled ONLINE. The price quoted by the bidder only in the dynamic schedule shall be considered for price bid evaluation.

2. BID OPENING :

The bid shall be opened in the following sequence:

- (i) First of all, the Part-I i.e. Techno-commercial part shall be opened.

Contractor

For & on behalf of SJVN Ltd.

- (ii) The Part-II i.e. Price bid shall be opened of only those firms whose Part-I of bid found techno commercially responsive. Necessary information will be given to successful bidders through website only.
3. Tender for works shall remain open for acceptance for the period of ninety (90) days from the date of opening of tenders.
4. **Cost of Bid Document and Earnest Money deposit (EMD/ Bid Security)**
- 4.1 The cost for purchase of bid document is **Rs. 3540- (Rupees Three thousand five hundred forty only) (Non-refundable) i.e. (Rs. 3,000/-+GST @18% i.e. Rs. 540/-)..**
- 4.2 **EMD/Bid Security:** The bidder shall furnish, a bid security/ earnest money as part of the bid amounting to **Rs. 81,861/- (Rupees Eighty One Thousand Eight Hundred Sixty One only). This EMD/Bid security is to be submitted through online or FDR/TDR as mentioned at 4.4 below.**
- 4.3 The "Cost of Bid document" & "Earnest Money Deposit (EMD)" shall be submitted / deposited through online payment gateway on SRM Portal/e-tendering portal.
Caution: In the event of funds remitted to wrong beneficiary account number, **SJVN Limited** or its Bank or its service provider would not responsible for the same.
- 4.4 **FDR/TDR:** Please note that EMD (Earnest Money Deposit)/ Bid Security in the form of **FDR/TDR (Pledged in favour of the NJHPS, SJVN Limited)** is also acceptable. The EMD (Earnest Money Deposit)/ Bid Security in the form of **FDR/TDR** shall have to be submitted by the deadline of submission of physical documents indicated above at Sr. No. 1 (A) (a) (I, II & III) in a sealed envelope through post / courier or by hand on the address of HOD (P&C), NJHPS, SJVN Ltd., Jhakri, Tehsil Rampur Bsr., Distt. Shimla (HP)-172201, failing which the bid shall be considered as non-responsive & financial bid will not be opened.
- Remarks: - The EMD submitted in the form of BG, DDs, local Cheque/ outstations Cheque will not be considered.**
- 4.5 Bid security shall remain valid for a period of 45 days beyond the original bid validity period and beyond any extension subsequently requested. Any correction, alteration and addition in computer generated / other hand written instrument subsequently needs to attested by the appropriate authority of bank.
- 4.6 **Being Civil work tender MSEs/NSIC/Startup India registered firms are not exempted from the submission of Cost of Tender Document & Earnest Money Deposit/Bid Security.**
- 4.7 EMD of the bidder shall be forfeited/necessary action may be taken as per bid security declaration, if the bidder withdraws or amends its bids or impairs or derogates from the bid in any respect with in the period of validity of the bid. ***The EMD of the successful bidder shall be retained as contract security until such period the contractor furnishes the required security deposit and shall be released within 30 days from the receipt of the performance security & verification/confirmation thereof.*** If the contractor is failed to fulfill his obligations, the EMD, retained as contract security shall be forfeited/necessary action may be taken as per bid security declaration submitted by the firm along with their bid.

Contractor

For & on behalf of SJVN Ltd.

- 4.8 The bid securities/EMD of unsuccessful bidders shall be returned within thirty (30) days after the declaration of result of 1st stage i.e technical evaluation.
- 4.9 **EMD of bidder(s) will be refunded only to designated account submitted by the bidder at the time of registration with SJVN irrespective of mode of payments made.**
- 4.10 **No interest shall be payable by the SJVN on EMD.**
- 4.11 **Tender without cost of document & Bid security/EMD will be rejected.**

5. **Qualification requirements :**

Before the submission of bids the bidder in his own interest ensures that he meets the requisite qualification criteria as given below and shall upload copies of the same along with the techno-commercial bid: -

SJVN Limited has to finalize its tender within a limited time schedule. Therefore it may not be feasible in all case for SJVN Limited to seek clarifications in respect of incomplete offers. The decision will be made based on available documents. Prospective bidders are advised to ensure that their bids are complete in all respects and confirm to our terms and conditions. Bids not complying with SJVN Limited requirements may be rejected without seeking any clarifications.

- (A). The intending Tenderer must have their registration / license, PAN, GST No., EPF Code No. etc. and upload along with their Techno- commercial bid.
- (B) Eligibility for the tender shall be restricted to those parties / contractors who will fulfill the following conditions and upload documentary proof:-
- (i) **Financial Turnover:** The Average Annual Financial turnover of the bidder during the last three (03) years, ending 31st March 2025 should be at least **Rs. 12,27,922/- (Rs. Twelve Lakh Twenty Seven Thousand Nine Hundred Twenty Two only).**

Remarks: Annual financial turnover should be supported by Annual Report (Balance Sheet and Profit & Loss Statement) of last 3 (three) years ending 31/03/2025. In case the financial turnover of previous financial year 2024-25 is not finalized till the submission of bid, the provisional financial turnover for the year ending 31/03/2025 should be submitted by the bidder duly authenticated/audited by the concerned statutory auditor or an authorized practicing Chartered Accountant or an authorized firm of Chartered Accountants.

- (ii) **Work Experience:** The bidder should have an experience of having successfully completed similar works/contracts as any of the following criteria during last seven (07) years ending last day of month previous to the one in which applications are invited should be either of the following:
- (a) Three similar completed works costing not less **₹ 16,37,229/- (Rupees Sixteen Lakh Thirty Seven Thousand Two Hundred Twenty Nine only)** each.
- OR**
- (b) Two similar completed works costing not less than **₹ 20,46,536/- (Rupees Twenty Lakh Forty Six Thousand Five Hundred Thirty Six only)** each.

OR

Contractor

For & on behalf of SJVN Ltd.

- (c) One similar completed work costing not less than ₹ 32,74,458/- (Rupees Thirty Two Lakh Seventy Four Thousand Four Hundred Fifty Eight only) .

***Remarks: - The above-mentioned values are exclusive of taxes.**

Note:-

- (i) *Similar Works means works related to:- “Civil work which involves the execution of most of the items related to the B.O.Q. of this work and/or civil work of higher specification.”*
- (ii) *In the support of similar work experience, the bidder must have to submit/upload documentary proof of the work experience along with copies of the B.O.Q. of the executed work. In case documentary proof of work experience is issued by private company (ies) /firm (s), then copy (ies) of TDS for the same work are also needs to be submitted by the bidder.*
- (iii) *Further any short full documents i.e LOA/BOQ/Completion certificate/TDS etc. for the already submitted “work experience” along with bid can be sought. However, NO new work experience/LOA/ Contract shall be asked during the evaluation of bids.*

Remarks:- Being Civil work MSEs/NSIC/Startup India registered firms are not relaxed from the condition of Prior Financial turnover and prior work done experience . MSE 's/NSIC/Startup India registered firms have to submit/upload financial turnover and work done experience certificate of similar work fulfill independently as per Qualifying criteria of tender

- (C) The above mentioned requirements are minimum and the **SJVN Limited**, reserves the right to ask for any additional information.

6. Not with standing anything stated above, the **SJVN Limited** reserves the right to assess bidder’s capability and capacity to perform the works, should the circumstances warrant such an assessment in the overall interest of the **SJVN Limited**.
7. The item of work is given in the Bill of Quantities along with estimated rate & amount of the Bidding Documents. The Bidder shall be required to offer their rates and prices in %age (i.e. upto two (02) decimal places) for the whole work, which shall include material, labour, equipment, taxes & duties etc. except **GST**.

The applicable GST shall be released separately on submission of GST invoice as per GST act.

8. Payment Procedure:

If the payment due to the Contractor for any undisputed amount for which interim bill has been approved by the Engineer – in – Charge, is delayed by more than **15 days** from the due date of payment (i.e. **45 days** from date of submission of bill) an interest @ of 8% per annum and acceptance thereof by Engineer in Charge, shall be payable to the Contractor for the actual number of days of delay in payment of bill beyond the above said period of **15 days**.

in case of Micro & Small Enterprise (MSE) following provision shall apply :

All the payments for the supplies and/or services (as applicable) rendered by MSEs (Micro & Small Enterprises) supplier/Contractor under the contract shall be released within forty five (45)

Contractor

For & on behalf of SJVN Ltd.

days from the day of acceptance, subject to submission of invoice on or before the day of acceptance.

Day of acceptance means day of actual delivery of Plant or the rendering of services; or where any objection is made in writing by SJVN regarding acceptance of Plant or service within fifteen days from the date of delivery of Plant or the rendering of services, the day on which such objection is removed by the contractor/supplier.

In case payments are not released as mentioned above, SJVN shall pay the principal amount plus compound interest with monthly rests from the date immediately following the date agreed upon @ three times of bank rates as notified by Reserve Bank of India from time to time.

- 09 The successful bidder must submit the attested copy of valid labour license in the O/o Engineer Incharge before start of work at site.
- 10 The work will be awarded to L-1 bidder whose bid will be found substantially responsive on overall basis. The tender has been invited on one %age figure (i.e. at par/ above / below basis). Bidder has to quote the %age unit rate in figure upto 2 decimal places and same shall be applicable uniformly on all items of Annexure-A. For example, if a bidder has quoted 5 %, the same shall be considered as 5.00%.

11. Correction of Errors (Applicable to extent possible).

The prices are to be filled in ONLINE DYNAMIC Schedules as under:-

- A. The bidder has to fill the Unit Rates in %age only after selecting at par/above/below option up to 2 decimal places.**
- B. The entered %age in figures shall be automatically converted in to total amount.**

12. Corrupt or Fraudulent Practices

It is expected from the bidders/Contractor and/or any of its personnel, or its agents, or its Sub-contractors, manufacturer, sub-consultants, services providers, suppliers and/or their employees that they will observe the high standard of ethics during the bidding process and execution of such Contracts. In pursuance to this policy:

- a) For the purpose of this provision, the terms set-forth below shall mean as under:
- i) "Corrupt practice" means the offering, giving, receiving or soliciting of anything of value to influence the action of a public official in the procurement process or in Contract execution.
- ii) "fraudulent practice" means a misrepresentation or omission of facts in order to influence a procurement process or the execution of a contract to be detriment of the Employer, and includes collusive practice among Applicants (prior to or after bid submission) designed to establish bid prices at artificial non-competitive levels and to deprive the Employer of the benefits of free and open competition.
- b) A Bid shall be rejected by the Employer if it is determined at any stage that respective bidders / Contractor and/or any of its personnel, or its agents, or its Sub-contractors, manufacturer, sub-consultants, services providers, suppliers and/or their employees has engaged in corrupt or fraudulent or collusive practices in competing for the Contract in question.
- c) The Employer will declare a bidder/contractor ineligible or may terminate the **Contractor** **For & on behalf of SJVN Ltd.**

contract, either indefinitely or for a stated period of time, to be awarded a Contract if it at any time determines that the bidders/Contractor and/or any of its personnel, or its agents or its Sub-contractors, manufacturer, sub-consultants, services providers, suppliers and/or their employees has engaged In corrupt or fraudulent or collusive practices In competing for or in executing the Contract In question.

- d) All the bidders/service providers/vendors /consultants etc. shall be requested to furnish a certificate regarding presentation and detection of fraud as per **Annexure-D along with Annexure II of Guidelines on Banning of Business Dealings.**
- e) Any fraud / suspected cases involving bidders/ contractor/ supplier/ consultant or any outside party required action, if any, shall be taken by SJVN as may be deemed fit in the respective cases depending upon the outcome of the investigation carried out in line with the Investigation procedure mentioned in “**Fraud prevention and detection policy of SJVN**”

13. Procurement of Goods/Services/Works from Local Suppliers under Public Procurement (Preference to Make in India), 2017 and revised PPP MII order, dated 16-09-2020 and MOP orders dated 20-12-2018 & 28-07-2020.

DPIIT issued PP (PMI) Order 2017 for encouraging Make in India and promoting domestic manufacturing. Pursuant to DPIIT orders, MOP notified in December, 2018 Purchase Preference (Linked with local content) for Thermal, Hydro and Transmission Sub-sectors and for distribution sector vide order dated 17.03.2020. DPIIT issued a revised PPP MII order, dated 16-09-2020 and MOP orders dated 20-12-2018 & 28-07-2020.

Local Content:- ‘Local Content’ means the amount of value added in India which shall, unless otherwise prescribed by the Nodal Ministry, be the total value of the item procured (excluding net domestic indirect taxes) minus the value of imported content in the item (including all custom duties) as a proportion of the total value, in percent.

Class-I local supplier:- ‘Class-I local supplier’ means a supplier or service provider, whose goods, services or works offered for procurement , has minimum 50% local content, as defined in DPIIT order dated 16-09-2020.

- (i) *In line with the DPIIT PPP-MII order dated 16.09.2020 and MOP orders dated 20.12.2018 & 28.07.2020, “Only Class-I Local Supplier” shall be eligible to bid in this tender and the bidder shall upload the Self-Certification as per Annexure-E, certifying that the item offered meets the Local Content requirement for Class-I Local Supplier, on letter head of Firm.*
- (ii) “Self-declarations/ auditor’s/ accountant’s certificates submitted by the manufacturer/ supplier may be verified randomly by the committee constituted as per MOP Order 28-07-2020. In case of false documents/misrepresentation of the facts requisite action against such manufacturer/ supplier will be taken based on the recommendation of the Committee”.

Contractor

For & on behalf of SJVN Ltd.

- 14 Bill Tracking System:** Prior to the submission of the bills in physical form, supplier shall submit the bills in SJVN vendor bill tracking portal available in SJVN official website <https://www.sjvn.nic.in> under quick link section. Further, supplier may track the status of bills online through Vendor Bill tracking system. In order to use this system, a user manual for supplier is available under Vendor bill tracking system section. Supplier is required to enter the user ID, password and OTP (one time password) for every log in. The user ID and password shall be obtained from the concerned department of SJVN Ltd. However, the OTP will be received to the supplier in the registered mobile number provided by supplier to the concerned department. Once the supplier has received its username and password from the concerned department, supplier shall follow the below mentioned steps:
- (i) Once supplier received the user ID and password from the concerned department, the supplier can log in to vendor bill tracking system with user ID, password and OTP.
 - (ii) After log in, supplier shall enter the details required in the vendor portal screen and submit the invoice specifically to the concerned SJVN official's email ID (abcd@sjvn.nic.in), after submission a unique VITMS number (Reference Number) will be generated and supplier will receive an automated unique VITMS number (Reference Number) both in its automated unique email ID and mobile number.
 - (iii) On receipt of the physical bill, concerned SJVN official shall online acknowledge the receipt of the bill. All the actions taken by the concerned officials of SJVN can be easily been tracked in the "Invoice Status Section" by supplier.
 - (iv) After the final payment, vendor can download the details of the payment under check forwarding details section on the invoice upload and track screen.
15. The bids in physical form /Conditional / telegraphic tenders or tenders without earnest money shall not be considered.
16. If it happens to be holiday or poor internet connectivity on the date of receipt / opening of the tenders, the same shall be opened on the next working day at the same time.
17. SJVN Ltd. reserves the right to accept or reject any or all tenders without assigning any reasons thereof.
18. SJVN Limited reserves the right to cancel/withdraw the invitation for bid without assigning any reason and shall bear no liability whatsoever consequent upon such a decision
19. In case of any contradiction between Hindi & English version of NIT, the provision of English version of NIT will prevails.
20. **SIGNING OF THE CONTRACT AGREEMENT.**
- ▶ **The contract agreement shall be signed at NJHPS, SJVN, Jhakri (INDIA) in the office of undersigned within 15 days from the date of issue of LOA.**
 - ▶ The Contract Agreement (s) will be signed in two (02) originals on non-judicial Stamp Paper (02 Nos) of ₹ 100/- each along with two (02Nos) copies of judicial paper of ₹ 1/-each within fifteen (15) days from the issue of Notification of awards/letter of Awards ***The non-judicial stamp papers & judicial papers are to be purchased from Himachal Pradesh only.***
 - ▶ The agreement shall be signed by the authorized signatory of service provider/contractor, **While signing of agreement, satisfactory evidence of authority of the Authorized Signatory signing on behalf of the service provider shall be furnished on non-judicial stamp paper of an appropriate value in the form of a Power of Attorney/Authorization Letter, duly notarized by a Notary Public, indicating that the Authorized Signatory**

Contractor

For & on behalf of SJVN Ltd.

signing the agreement have the authority to sign the agreement and that the agreement is binding upon the service provider.

21. RESTRICTIONS IMPOSED BY GOVT OF INDIA:

Any bidder from a country which shares a land border with India will be eligible to bid in this tender only if the bidder is registered with the Competent Authority specified in Annexure-I of Ministry of Finance, Government of India order no F. No. 6/18/2019-PPD dated 23.07.2020 and various amendment/clarification issued in this regard. The bidders for the purpose of compliance and its procedure for registration from Competent Authority etc. The bidder has to submit the undertaking as per **Annexure-H (enclosed)** regarding compliance of above-mentioned order. In case the undertaking given by the bidder whose tender has been accepted by the Employer is found false at the later stage, this would be a ground for immediate termination and further legal action shall be taken in accordance with law.

**Head of Dept.(HOD)
Procurement & Contract Deptt.,NJHPS,
SJVN Ltd., Jhakri, Distt. Shimla (HP).**

Contractor

For & on behalf of SJVN Ltd.

Section-1

Information's and instructions for tenderers

1. The tender documents will state the work to be carried out as well as the date of submitting and opening of tenders and the time allowed for carrying out the work, the amount of earnest money to be deposited with the tender and the percentage at which the security deposit shall be deducted from the bills of the successful tenderers.
2. In the event of the tender being submitted by a firm, it must be signed separately by each partner thereof, or in the event of the absence of any partner, it must be signed on his behalf by a person holding a power of attorney authorizing him to do so, such power of attorney to be produced with the tender, and it must disclose that the firm is duly registered under the Indian partnership Act.
3. Receipt for payments made on account of work, when executed by a firm, must also be signed by the several partners, except where the contractors are described in their tender as a firm, in which case the receipts must be signed in the name of the firm by one of the partners, or by some other person having authority to have effectual receipts for the firm.
4. The firm who submits upload a tender shall fill up the schedule of quantities annexed at Schedule-I of tender documents, stating at what rate they are willing to undertake each item of the work. No single tender shall include more than one work, but contractors who wish to tender for two or more works shall submit a separate tender for each work. Tender cost & EMD shall have the name and tender reference number of the work to which they refer, written outside the envelope.
- 4 A The rates and/or amounts must be quoted in decimal coinage upto two places of decimals.
5. Incharge PCD or persons duly authorised by him will open tenders in the presence of any intending contractor who may be present at the time and will enter the amount of the several tenders in a comparative statement in a suitable form.
6. The officer inviting tenders shall have the right of rejection of all or any of the tenders without assigning any reason there of and will not be bound to accept the lowest tender.
7. The memorandum of work tendered for the schedule of material to be supplied by the SJVN Limited and their issue rates, shall be filled in and completed before the tender documents is issued. If a form is issued to an intending Tenderer without having been so filled in and complete, he shall request the officer to have this done before he completes and delivers his tender.

Contractor

For & on behalf of SJVN Ltd.

8. i) The tenders shall abide by all the terms and conditions contained in the tender documents and quote their rates accordingly. The conditional tenders shall not be accepted and shall be summarily rejected.
 - ii) Tenders without required amount of earnest money shall be summarily rejected.
 - iii) The security deposit of the successful bidder will be forfeited if he fails to comply with any of the condition of the contract and any stipulation thereof.
9. In case of ambiguities in rates and amount in the tender, the rate shall prevail and the amount shall be corrected. In case of ambiguities in the rate in figures and the rate in word, the rate quoted in word shall prevail and the amount shall be corrected accordingly. The SJVN reserves the right to adjust arithmetical or other errors in any tenders in the way which it consider suitable.
10. Only in case of conventional bidding system tenders shall be submitted in two separate sealed envelopes, one containing the earnest money and an undertaking to the effect that there is no deviation from the standard terms and conditions of the tender document and the other containing the price bid. The first envelope shall be opened on the date fixed for opening of tenders and the second envelope containing price bid shall be opened only if earnest money and an undertaking regarding terms and conditions as stated above are enclosed with the tender.
11. Tenders are to be submitted in original only in respect of schedule of quantities i.e. for conventional bidding system only.
12. For conventional bidding system only Tenders shall be submitted as per Sr. No. 10 above with the name of work written on the envelopes.
13. The site for the work is available.
14. A tenderer should quote in figures as well as in words rate (s) tendered. The amount for each item should be worked out and the requisite totals given Special care shall be taken to write rates in figures as well as in words and the amounts in figures shall be written only in such a way that interpolation is not possible. The total amount shall be written both in figures and in words. In case of figures the words 'Rs' should be written before the figure of rupees and the words paise after the decimal figures e.g. Rs. 2. 15 p and in case of words the words Rupees should precede and the words "paise" should be written at the end. Un-less the rate is in whole rupees and followed by the word only it should invariably be up to two places of decimal.
15. Earnest money (unless exempted @ 2.36% of the estimated cost should be deposited by each tenderer in any one of the following forms payable at any schedule bank favouring. SJVN Ltd. Jhakri. **(This clause may be read as per Sr. No. 2 of Additional Special Terms & Conditions of contract (Annexure-"C"of tender document)**

Contractor

For & on behalf of SJVN Ltd.

- a) Fixed deposit receipt issued by scheduled banks endorsed in favour of SJVN Ltd. Jhakri.
 - b) The Earnest Money Deposit at call shall not attract interest from the SJVN Limited.
 - c) EMD submitted by the contractor may be forfeited on the following grounds :-
 - i) On revocation of the tender or revision in rates after opening of the tender but before the validity of the quotation expires.
 - ii) On refusal to enter into a contract after the award of contract.
 - iii) If the work is not commenced after the work is awarded to a contractor.
16. The tenderer, whose tender is accepted (unless exempted) will be required to furnish security deposit for the due fulfilment of his contract.

The Security Deposit shall comprise the following:

- i. Performance Security Deposit to be furnished by the Contractor within 15 days from the date of issuance of Letter of award.
 - ii. Retention Money to be recovered from Interim bills of the Contractor.
- (a) The Contractor within 15 (Fifteen) days from the date of issuance of Letter of Award, shall furnish a **Performance security deposit of 3% (Three percent)** of the Contract Price for due performance of contract. The Performance Security Deposit shall be in the form of a FDR pledged to SJVN Ltd. issued by a Nationalized/ Scheduled Indian Bank located in India acceptable to SJVN Ltd.

Note:

- (i) The interest @15.5% shall be charged on delay period for breach in timely submission of Performance Security deposit without prejudice to right of SJVN to other remedies available under the contract. The GST shall be levied & recovered extra on interest as per applicable rule of GST.
 - (ii) In case last day of submission of performance security deposit happens to be a bank holiday, the last day of submission shall be the next working day.
- (b) **Retention money shall be deducted by the Engineer-in-Charge from the interim bills of the Contractor @ 3% (three percent)** of the total value of each bill of the work done towards security deposit.
- (b) The security deposit shall be valid for a period of six months beyond the date of issue of completion certificate. The security deposit shall not attract any interest from SJVN Limited.

Note: The clauses mentioned at Sr. No. 16 (a), (b), (c) & (d) above may be read as per Sr. No. 4 of Additional Special Terms & Conditions of Contract (Annexure-"C" of tender document)

17. The Chairman SJVN Ltd. or his official representative/nomine who has been assigned with the job shall be the Accepting Authority of this tender.
18. The SJVN Limited does not bind themselves to accept the lowest or any tender or to give any reason for their decision.

Contractor

For & on behalf of SJVN Ltd.

19. The SJVN Limited reserves to themselves the right of accepting the whole or any part of the tender and tenderer shall be bound to perform the same at his quoted rates.
20. Canvassing in connection with tenders is strictly prohibited and tenders submitted by the contractor who resort to canvassing will be liable to rejection.
21. All rates shall be quoted on the proper form of the tender alone.
22. Item rate tenders containing certain percentage below/above the rate indicated in the reference a will be summarily rejected.
23. On acceptance of the tender, the name of accredited representative (s) of the contractor who would be responsible for taking instructions from the Engineer-In-Charge shall be communicated to the Engineer-In-Charge.
24. Sales tax or any other tax on material in respect of this contract shall be payable by the contractor and SJVN Limited will not entertain any claim whatsoever in this respect.
25. The contractor shall not be permitted to tender for works in the SJVN Limited if his near relatives is posted as Accountant, Divisional Head Draughtsman or as an officer in any capacity between the grade Superintending Engineer and Assistant Engineer (both inclusive). He shall also intimate the names of persons who are working him in any capacity or are subsequently employed by him and who are near relative of any gazetted officer of any responsible post in SJVN Limited Any breach this condition by the contractor would render him liable to be removed from the approved list of contractor of the corporation.
26. The contractor shall give a list of non-gazetted SJVN Limited employees related to him.
27. No Engineer of Gazetted rank or other gazetted officer employed in Engineering Administrative duties in an Engineering department of the Govt. is allowed to work as a contractor for a period of two years of his retirement from Government service, without the period permission of the SJVN Limited The contractor is liable to be cancelled if either the contractor or any of his employees is found at any time to be such a person who has not obtained the permission of the SJVN Limited as aforesaid before submission of the tender or engagement in the contractors service.
28. Tender for works shall remain open for acceptance for a ninety days from the date of opening of tenders.
29. Contractor exempted from payment of Earnest money/security deposit in individual cases should attach with the tender, attested copy of the SJVN Limited letter exempting them from the payment of earnest money and Security deposit and should produce the some in original whenever called to do so.

Contractor

For & on behalf of SJVN Ltd.

30. The tender for the work shall not be witnessed by a contractor or contractors who himself/themselves has/have tendered or who may have quoted for the same work. Failure to observe this condition would render tenders of the contractor, tendering as well as witnessing the tender liable to summary rejection.

Contractor

For & on behalf of SJVN Ltd.

Section – II

Item Rate or Percentage Rate tender for works

I/We hereby tender for the execution, for the SJVN Limited, of the work specified in the under written memorandum within the time specified in such memorandum in accordance, in all respects, with the specification, designs, drawings and instructions in writing referred to in rule 1 hereof and in clause 11 of the conditions of contract and with such materials as are provided for by and in all other respect in accordance with such conditions so far as applicable.

Memorandum.

- (a) General description **As per NIT**
- (b) Estimated cost **Rs. 40,93,072/- (exclusive of GST)**
- (c) Earnest Money @2% of the estimated cost.
- (d) Security Deposit as per Sr. No. 16 of Information and Instructions for tenderers.
- (e) Time allowed for the work from the fifteenth day after the date of written order to commence the work is **Five (05) months.**

Should this tender be accepted, in whole or in part, I/We hereby agree.

- (i) To abide by and fulfill all the terms and provisions of the said conditions annexed here to and all the terms and provisions contained in notice inviting tenders so far as applicable and/or in default thereof to forfeit and pay to the SJVN Limited or its successors in office, the sum of money mentioned in the said conditions. A sum of **Rs. 81,861/-** is hereby forwarded as Earnest Money. If I/We fail to commence the work specified in the above memorandum, I/We agree that the said SJVN Limited or its successors in office shall, without prejudice to any other right or remedy, be at liberty to forfeit the said earnest money absolutely, otherwise the said Earnest Money shall be retained by it towards security deposit mentioned against clause (d) of the above mentioned Memorandum.
- (ii) To execute all the works referred to in the tender documents upon the terms and conditions contained or referred to therein and to carry out such deviations as may be ordered upto a maximum of twenty percent at the rates quoted in the tender documents and those in excess of that limit at the rates to be determined in accordance with the provisions contained in clause-12 A of the tender document.

Signature of the Contractor

Dated the.....Day of.....202

Witness.....

Address.....

Occupation.....

Contractor

For & on behalf of SJVN Ltd.

The above tender for the sum of Rs.....

(Rupees.....)

is hereby accepted by me..... on behalf of SJVN Limited.

Dated the.....day of.....202
.....

(Designation of Officer)

Contractor

For & on behalf of SJVN Ltd.

Section - III
General conditions of contract

Definitions:

- (1) The "Contract" means the documents forming the tender and acceptance thereof and the formal agreement executed between the SJVN Limited, and the contractor, together with the documents referred to therein including these conditions, the specifications, designs drawings and instructions, issued from time to time by the Engineer-In-Charge and all these documents taken together shall be deemed to or one contract and shall be complementary, to one and another.
- (2) In the contract the following expression shall unless the context otherwise requires, have the meanings hereby respectively assigned to them.
 - a) The expression 'work' or 'works' shall, unless there be something either in the subject or context repugnant to such expressions, be construed and taken to mean the works by or by virtue of the contract, to be executed, whether, temporary or permanent and whether original, altered, substituted or additional.
 - b) The 'Site' shall mean the land and/or other places on, into or through which work is to be executed under the contract or any adjacent land, path or street, which may be allotted or used for the purpose of carrying out the contract.
 - c) The 'Contractor' shall mean the individual or firm or company whether incorporated or not, undertaking the works and shall include the legal personal representative or such individual or the persons composing such firm or company, or the successor of such firm or company and the permitted assigns of such individual or firm or Company.
 - d) The corporation shall mean SJVN Limited.
 - e) The word 'Engineer'/'Engineer-In-Charge' means the Engineer nominated by SJVN Limited under whose supervision the work shall be carried out.

Clause - 1 : The person whose tender may be accepted (herein after called the contractor) shall permit Corporation, to deduct such sum(s) towards Security Deposit after considering the Earnest Money already deposited.

Such deductions shall be held by Corporation towards the Security Deposit as mentioned at Sr. No. 16 of "Information and Instruction for Tenders" provided always that the corporation for this purpose shall be entitled to recover 3% (three percent) of the amount of RA bill or at proportionate rate by which the balance Security Deposit bears to the contract value whichever is higher.

Contractor

For & on behalf of SJVN Ltd.

Any compensation or other sums payable by the contractor in terms of this contract may be deducted from or paid out of the Security Deposit and in the event of Security Deposit being reduced by reason of any such deductions, the contractor shall within 10 days make good either by deposit cash or Bank draft.

Clause - 2: The time allowed for carrying out the work as entered in the tender shall be strictly observed by the Contractor and shall be deemed to be essence of the contract on the part of the contractor and shall be reckoned from the 15th day after the date on which order to commence the work is issued to the Contractor. The Contractor shall be bound in all cases in which the time allowed for any work exceeds one month (say for special jobs) to complete 1/8th of the whole of the work before 1/4th of the whole time allowed in the contract has elapsed, 3/8th of the work before 1/2 of such time has elapsed and 3/4th before 3/4th of such time has elapsed. However for special jobs, if a time schedule has been submitted by the Contractor and has been accepted by Engineer-In-Charge, the Contractor shall comply with the said time schedule. The work shall throughout the stipulated period of the contract be proceeded with all due diligence. If the Contractor fails to maintain the required progress to complete the work and clear the site on or before the contract or extended date of completion, he shall, without prejudice to any other right or remedy of the Corporation on account of such breach, pay as compensation an amount calculated as stipulated below or such smaller amount as may be decided by the contract approving authority on the contract value of the work for every week that the work remains un-commenced or unfinished after the schedule dates or the progress remains below than the progress rate specified above."

This will also apply to items or groups of items for which separate period of completion has been specified.

For this purpose the term "Contract value" shall be the value at contract rates of the work as ordered.

- a) Completion period (as originally stipulated) not exceeding 6 (six) months: @ 1% per week.
- b) Completion period (as originally stipulated) exceeding 6 (six) months and not exceeding two years: @ 1/2% per week.
- c) Completion period (as originally stipulated) exceeding two years: @ 1/4% per week.

Provided always that the total amount of compensation for delay to be paid under this condition shall not exceed 10% of the contract value or of the contract value of the item or group of items of work for which a separate period of completion is given. The GST shall be recovered extra on L.D. Charges as per applicable GST rule.

The amount of compensation may be adjusted or set off against any sum payable to the contractor under this or any other contract with the corporation. If the liquidated damages are levied on any item of work on account of delay in some milestone and if the contractor achieves the next milestone within specified time, the liquidated damages already levied for that item shall be refunded.

Contractor

For & on behalf of SJVN Ltd.

Clause - 3 : The Engineer-In-Charge may without prejudice to this right against the contractor in any respect of any delay or inferior workmanship or otherwise or to any claims for damage in respect of any breaches of the contract and : without prejudice to any right or remedies under any of the provisions, of this contract or otherwise and whether the date for completion has or has not elapsed, by notice in writing absolutely determine the contract in any or the following cases :

(i) If the contractor having been given by Engineer-In-Charge a notice in writing to rectify, reconstruct or replace any defective work or that the work is being performed in any inefficient or otherwise improper or un-workman like manner, shall omit to comply with the requirements of such notice for a period of seven days, thereafter or if the contractor shall delay or suspend the execution of the work so that either in the judgment of the Engineer-In-Charge (which shall be final and binding), he will be unable to secure completion of the work by the date for completion or he has already failed to complete the work by that date.

(ii) If the contractor being a company shall pass a resolution or the court shall make an order that the company shall be wound up or if a receiver or manager on behalf of a creditor shall be appointed or if circumstance shall arise which entitle the court or creditor to appoint a receiver or a manager or which entitle the court to make a winding up order.

(iii) If the contractor commits breach of any of the terms and conditions of this contract.

(iv) If the contractor commits any acts mentioned in clause - 21 hereof.

When the contractor has made himself liable for action under any of the cases aforesaid, the Engineer-In-Charge on behalf of the NJHPS shall have powers.

(a) To determine or rescind the contract as aforesaid (for which termination or rescission notice in writing to the contractor under the hand of the Engineer-In-Charge shall be conclusive evidence). Upon such determination or rescission, the security deposit of the contractor shall be liable to be forfeited and shall be absolutely at the disposal of SJVN.

b) To employ labour paid by the SJVN and to supply materials to carry out the works or any part of the work debiting the contractor with the cost of the labour and the price of the material (of the amount of which cost and price certified by the Engineer-In-Charge shall be final and conclusive, against the contractor) and crediting him with the value of the work done in all respects in the same manner, at the same rates as if it had been carried out by the contractor, under the terms of the contract. The certificate of the Engineer in-charges to the value of the work done shall be final and conclusive against the contractor, provided always that action under the sub-clause shall only be taken after giving notice in writing to the contractor. Provided also that if the expenses incurred by the SJVN are less than the amount payable to the contractor at his agreement rates, the difference shall not be paid to the contractor.

(c) After giving notice to the contractor to measure up the work of the contractor and to take such part thereof as shall be unexecuted out of his hands and to give it to another contractor to complete in which case any expenses which may be incurred in

Contractor

For & on behalf of SJVN Ltd.

excess of the sum which would have been paid to the original contractor, if the whole work had been executed by him of the amount of which excess (the certificate in writing of the Engineer-In-Charge shall be final and conclusive), shall be borne and paid by the original contractor and may be deducted from any money due to him by SJVN under this contract or on any other account whatsoever or from his security deposit or the proceeds of sales thereof or a sufficient part thereof, as the case may be.

In the event of any one or more of the above courses being adopted by the Engineer-In-Charge, the contractor shall have no claim to compensation for any loss sustained by him by reason of his having purchased or procured any materials or entered into any arrangements or made any advances with a view to the execution of the work or the performance of contract. And in case action is taken under any of the provisions aforesaid, the contractor shall not be entitled to recover or be paid any sum of any work thereto or actually performed under this contract unless and until the Engineer-In-Charge has certified in writing the performance of such work and the value payable in respect thereof and he shall only be entitled to be paid the value so certified.

Clause - 4 : In any case in which any of the powers conferred upon the Engineer-In-Charge by clause-3 hereof, shall have become exercisable and the same shall not be exercised, the non-exercise thereof shall not constitute a waiver of any of the conditions hereof and such powers shall notwithstanding be exercisable in the event of any future case of default by the contractor and the liability of the contractor for compensation shall remain unaffected. In the event of the Engineer-In-Charge putting in force all or any of the powers vested in him under the preceding clause he may, if he so desires after giving a notice in writing to the contractor, take possession of or (at the sole discretion of the Engineer-In-Charge which shall be final) use as on hire (the amount of hire money being also the final determination of the Engineer-In-Charge) all or any tools, plant, materials and stores, in or upon the works or the site thereof, belonging to the contractor, or procured by the contractor and intended to be used for the execution of the work or any part thereof, paying or allowing for the same in account of the contract rates or in the case of these not being applicable at current market rates to be certified by the Engineer-In-Charge whose certificate thereof shall be final, otherwise the Engineer-In-Charge by notice in writing may order the contractor or other authorized agent to remove such tools, plant, materials or stores from the premises (within a time to be specified in such notice) and in the event of the contractor failing to comply with any such requisition, the Engineer-In-Charge may remove them at the contractor's expense or sell them by auction

or private sale on account of the contractor and at his risk in all respects and the certificate of the Engineer-In-Charge as to the expenses of any such removal and the amount of the proceeds and expense of any such sale shall be final and conclusive against the contractor.

Clause - 5 : If the work (s) be delayed by :-

- i) Force Majeure, or
- ii) Abnormally bad weather, or
- iii) Serious loss or damage by fire, or

Contractor

For & on behalf of SJVN Ltd.

- iv) Civil commotion, local commotion of workman. strike or lockout affecting any of the trades employed on the work, or
- v) Delay on the part of other contractors or tradesmen engaged by Engineer-In-Charge in executing work not forming part of the contract, or
- vi) Non-availability of stores, which are the responsibility of the Corporation to supply under clause 10, or
- vii) Breakdown of tools and plants to be supplied or supplied by the Corporation under the provisions of the contract, or
- viii) Any other cause which, in the absolute discretion of the Corporation is beyond the Contractor's Control.

Then upon the happening of any such event causing delay, the Contractor shall immediately give notice thereof in writing to the Engineer-In-Charge but shall never the less use constantly his best endeavors to prevent or make good the delay and shall all that may be reasonably required to the satisfaction of the Engineer-In-Charge to proceed with the works.

Request for extension of time, to be eligible for consideration, shall be made by the Contractor in writing within 14 days of the happening of the event causing delay on the prescribed form giving full particulars and satisfactory evidence in support of such cause. The contractor may also, if practicable, indicate in such a request the period for which extension is desired.

Clause - 6 : Within ten days of the completion of the work the contractor shall give notice of such completion to the Engineer-In-Charge and within ten/ days of the receipt of such notice the Engineer-In-Charge shall inspect the work and if there is no defect in the work, shall furnish the contractor with a certificate of completion, otherwise a provisional certificate of completion indicating defects (a) to be rectified by the contractor and or (b) for which payments will be made at reduced rates, shall be issued, but no certificate of completion, provisional or otherwise shall be issued, not shall the work be considered to be completed until the contractor shall have removed from the premises on which the work shall be executed, all scaffolding surplus material, rubbish and all huts and sanitary arrangements required for his/their work people on the site in connection with the execution of the work as shall have been erected or constructed by the contractor (s) and cleaned off the dirt from all wood work, doors, windows, walls, floors or other parts of any building in upon or about which work is to be executed, or of which he may have had possession for the purpose of the execution thereof and not until the work shall have been measured by the Engineer-In-Charge. If the contractor shall fail to comply with the requirements of this clause as to removal of scaffolding, surplus materials and rubbish and all huts and sanitary arrangements as aforesaid and cleaning off dirt on or before the date fixed for the completion of the work, the

Engineer-In-Charge may at the expense of the contractor, remove such scaffolding, surplus materials and rubbish etc. and dispose off the same as he thinks fit and clean off such dirt as aforesaid and the contractor shall have no claim in respect of any

Contractor

For & on behalf of SJVN Ltd.

such scaffolding or surplus materials as aforesaid except for any sum actually realized by the sale thereof.

N. B. Ten days will apply in the case of work at the headquarters of the Engineer-In-Charge and thirty days will apply in case of works at a station other than the headquarters of Engineer-In-Charge.

Clause - 7 : No payment shall be made for a work estimated to cost Rupees ten thousand or less till the whole of the work shall have been completed and certificate of completion given. But in the case of work estimated to cost more than Rupees ten thousand, the contractor shall on submitting the bill be entitled to receive a monthly payment proportionate to the part thereof then executed to the satisfaction of the Engineer-In-Charge whose certificate of the sum payable shall be final and conclusive against the contractor. But all such intermediate payments shall be regarded payments by way of advance against the final payment only and not as payments for work actually done and completed, shall not preclude the requiring of bad, unsound and imperfect or unskilled, work to be removed and taken away and reconstructed or re-erected or be considered as an admission of the due performance of the contract, or any part thereof, in any respect or the accruing of any claim, not shall it conclude, determine or effect in any way, the powers of the Engineer-In-Charge under these conditions or any of them as to the final settlement and adjustment of the accounts or otherwise or in any other way vary or affect the contract. The final bill shall be submitted by the contractor within one month of the completion furnished by the Engineer-In-Charge and payment shall be made within three months if the amount of the contract plus that of the additional items is upto Rupees 2 Lacks (Rupees two lacks) and in 6 months if the same exceeds Rupees 2 Lacks (Rupees two Lacks) of the submission of such bill. If there shall be any dispute about any item of the work, than the undisputed item or items only shall be paid with in the said period of three months or six months as the case may be. The contractor shall submit a list the disputed items within thirty days from the disallowance thereof, and if he fails to do this his claim shall be deemed to have been fully waived and absolutely extinguished. Final bill of the contractor must accompany the certificate of the completion by the Engineer-In-Charge.

Clause - 8 : A bill shall be submitted by the contractor each month on or before the date fixed by the Engineer-In-Charge for all work executed in the previous month and the Engineer-In-Charge shall take or cause to be taken the requisite measurement for the purpose of having the same verified, and the claim, as far as admissible, adjusted as far as possible, before the expiry of ten days from the presentation of the bill. If the contractor does not submit the bill within the time fixed aforesaid, the Engineer-In-Charge may depute within seven days of the date fixed as aforesaid, a subordinate to measure up the said work in the presence of the contractor whose counter signature to the measurement list will be sufficient warrant; and the Engineer-In-Charge may prepare a bill from such list.

Clause - 8 A : Before taking any measurement of any work as has been referred to in clause 6, 7 and 8 hereof, the Engineer-In-Charge or a subordinate disputed by him shall give reasonable notice to the contractor. If the contractor fails to attend at the measurements

Contractor

For & on behalf of SJVN Ltd.

after such notice or fails to counter- sign or to record the difference within a week from the date of measurements in the manner required by the Engineer-In-Charge then in any such event, the measurement taken by the Engineer-In-Charge or by the subordinate deputed by him, as the case may be, shall be final and binding on the contractor and the contractor shall have no right to dispute the same.

Clause - 9 : The contractor shall submit all bills on the printed forms to be had on application at the office of the Engineer-In-Charge and the charges in the bills shall always be entered at the rates specified in the tender or in the case of any extra work ordered in pursuance of these conditions and not mentioned or provided for in the tender at the rates hereinafter provided for such work.

Clause - 9 A : Payments due to the contractor may, if so desired by him be made to his bank instead or direct to him, provided that contractor furnished to the Engineer-In-Charge (1) an authorization in the form of a legally valid document such a power of attorney conferring authority on the bank to receive payment and (2) his own acceptance of the correctness of the account made out as being due to him by SJVN or his signature on the bill or other claim preferred against SJVN before settlement by the Engineer-In-Charge of the account or claim by payment to the bank. While the receipt given by such bank shall constitute a full and sufficient discharge for the payment, the contractor should, wherever possible, present his bills only duly receipted and discharged through his bankers.

Nothing herein contained shall operate to create in favour of the bank any rights or equities vis-a-vis the SJVN.

Clause - 10 : Store supplied by the SJVN : If the specifications or schedule of items provide for the use of any special materials to be supplied from Engineer-In-Charge's store or if it is required that the contractor shall use certain stores to be provided by the Engineer-In-Charge as shown in the schedule of materials hereto annexed, the contractor shall be bound to procure and shall be supplied such materials and stores as are, from time to time, required to be used by him for the purpose of the contract only; and the value of the full quantity of the materials and stores so supplied and the rates specified in the said schedule of materials may be set off or deducted from any sums then due, or thereafter to become due to the contractor under the contract, or otherwise, or against or from the security deposit, or the proceeds or sale thereof if the same is held in Government securities the same or a sufficient portion thereof being in this case sold for the purpose. All materials so supplied to the contractor shall remain the absolute property of SJVN and shall not be removed on any account from the site of the work, and shall be at all times open to inspection by the Engineer-In-Charge. Any such materials, remaining unused and in perfectly good condition at the time of the completion or determination of the contract, shall be returned to the Engineer-In-Charge at a place directed by him, if by a notice in writing under his hand, he shall so require, but the contractor shall not be entitled to return any such materials unless with such consent, and shall have no claim for compensation on account of any such materials so supplied to him as aforesaid, not being used by him or for any wastage in or damages to any such materials; provided that the contractor shall in no case be entitled to any compensation or damage on account of any delay in supply or non-supply thereof of all or any such materials and stores; provided further that the contractor shall be bound to execute the entire work if the materials are supplied by the SJVN Limited within the

Contractor

For & on behalf of SJVN Ltd.

scheduled time for completion of the work plus 50% thereof (scheduled time plus 6 months if the time of completion of the work exceeds 12 months) but if a part only of the materials has been supplied within the aforesaid period, then the contractor shall be bound to do so much of the work as may be possible with the materials and stores supplied in the aforesaid period.

For the completion of the rest of the work, the contractor shall be entitled to such extension of time as may be determined by the Engineer-In-Charge whose decision in this regard shall be final.

Clause - 10 A : The Engineer-In-Charge shall have full powers to require the removal from the premises of all materials which in his opinion are not in accordance with the specifications and in case of default the Engineer-In-Charge is to be at liberty to employ other persons to remove the same without being answerable or accountable for any loss or damage that may happen or arise to such materials. The Engineer-In-Charge shall also have full power to require other proper materials to be substituted there or and in case of default the Engineer-In-Charge may cause the same to be supplied and all costs which may attend such removal and substitution, are to be borne by the contractor.

Clause - 10 B : The contractor on signing an indenture in the form to be specified by the Engineer-In-Charge, shall be entitled to be paid during the progress of the execution of work, 75 percent of the estimated value of any materials which are in the opinion of the Engineer-In-Charge non-perishable and are in accordance with the contract and which have been brought on the site in connection therewith and are adequately stored and/or protected against damage by weather or other causes but which have not at the time of advance been incorporated in the works. When materials on account of which an advance has been made under this sub clause are incorporated in the works, the amount of such advance shall be deducted from the next payment made under any of the clauses of this contract.

Clause - 10 C : If during the progress of the works, the price of any materials incorporated in the works, (not being a materials supplied from the Engineer-In-Charge's stores in accordance with clause 10 hereof) and or wages of labour increases decreases as a direct result of the coming into force of any fresh law or statutory rule or order (but not due to any changes in sales tax), the amount to be paid/recovered to from the contractor shall be adjusted for each quarter of calendar year for increase or decrease in the rates of labour and material as under:

(a) Price variation in labour cost:

Price variation in labour cost shall be computed by the following two methods viz; (i) & (ii). The amount payable to recoverable from the contractor will be the amount computed either under (i) or under (ii) which ever is higher.

(a) (i) If during the currency of the work, the minimum daily wage of unskilled labour increases/ decreases as a direct result of coming into force any fresh law or statutory rule or order, as applicable to District Shimla (H.P) a corresponding increase or decrease in payment to the contractor, shall be computed on the basis of the following formula:-

$$V = \frac{25\% \times R \times (W - W_0)}{\text{-----}}$$

Contractor

For & on behalf of SJVN Ltd.

Wo

Where

V = The amount of variation payable to/
recoverable from the contractor.

R = Value of work done after the date of increase/
decrease of daily wages during the quarter under review.

W = Revised minimum daily wages.

Wo = Minimum daily wages on the date of opening of tender.

The above adjustment will be allowed only after taking a certificate from the contractor that revised wages referred to above have been actually paid to the labour by contractor.

(a) (ii) If during the currency of the contract, there is an increase or decrease in the consumer price index number, for industrial workers in H.P. (General Index), a corresponding increase or decrease in the payment to the contractor shall be computed for each quarter on the basis of the following formula :-

$$V = \frac{25\% \text{ of } R \times I - I_0}{I_0}$$

Where V = Amount of variation payable to /recoverable from the contractor during the quarter under review.

R = Value of the work done during the quarter under review.

I₀ = Average Consumer Price Index Number for industrial workers in H.P. (General Index) for the quarter in which the tender had been submitted.

I = Average consumer price index number for industrial workers in H.P. (General Index) for the quarter under review.

Price indices indicated above shall be those published in 'Indian Labour Journal', Labour Bureau, Ministry of Labour, Government of India.

(b) Price Variation in cost of material :

(i) P.O.L.

The contract is based on the prices including tax levies etc. of P.O.L. as prevalent on the date of opening the tenders. Variation, if any, the these rates including taxes, duties or levies etc. shall be adjusted on the following basis.

The base price of high speed diesel oil, petrol, lubricants (viz. mobile oil grade SAE 30 and 40) shall be as per prices list of Indian Oil Corporation, Chandigarh. These commodities referred to above will be treated as representatives of all POL. the value of these commodities shall be taken as equivalent to 5% (five percent) of the total value of work put to tender.

Percentage of these three items constituting the P.O.L. will given as under.

High speed Diesel Oil-----75%

Contractor

For & on behalf of SJVN Ltd.

Petrol-----10%

Main Lubricants-----15%

Price variation i. e., increase or decrease in any of the above three items of P.O.L. will be adjusted on the above basis as illustrated below :

(Say) With (+) 10% variation in price of

high speed diesel oil 10% of 75% = 7.5% plus

(+) Zero % variation in

price of petrol Zero % of 10% = O.O. plus

and (+) 15% variation in price

of main lubricants of

grade 30 and 40 15 % of 15 = 2.25% plus

9.75% (+)

Therefore, increase in price payable to the contractor will be 9.75% x 5% i. e. 0.4875% of the value of work done after the date of increase in rates of HSD, Petrol and Lubricants referred to above.

If during the currency of the contract, there is an increase or decrease in the cost of POL carried to above, a corresponding increase or decrease in the payments to the contractor shall be computed as illustrated above for the work done in the quarter following the date of such increase or decrease.

(ii) All other materials:

If during the currency of the contract, there is an increase or decrease in the cost of material as reflected by the Index Number of Whole-sale price in India, all commodities (New Series base: 1993-94 = 100), a corresponding increase or decrease in the payments to the contractor shall be computed for each quarter on the basis of the following formula:

$V_m = 15\% \text{ of } R \text{ (m-mo)}$

mo

Where V_m = amount of variation payable to /recoverable from the contractor during the quarter under review.

R = Value of work done during the quarter under review.

m_o = Average Index No. of whole-sale prices in India

(new series base: 1993-94 = 100) all commodities.
for the quarter in which tender had been submitted.

m = Average Index number of whole-sale price in India
(new series base: 1993-94 = 100) all commodities,
for the quarter under review.

For the application of the above formula, the index number given in the Indian Labour Journal published by the Labour Bureau, Government of India shall adopted.

Contractor

For & on behalf of SJVN Ltd.

(c) The price variation shall remain operative for contract period as stipulated in this contract and authorised extension (s) thereof in case, the work is delayed due to contractor's fault or negligence, the contractor shall not get any benefit under this clause for the period of such delay.

(d) No adjustment for variation in price except those included in this clause shall be admissible.

(e) The price variation clause of 10 C (a) to 10 C (d) shall not apply to contract having completion period up to one year.

Clause - 10 D : The contractor shall treat all material obtained during dismantling of a structure, excavation of the site for a work etc, as SJVN property and such materials shall be disposed of to the best advantage of SJVN according to the instructions in writing issued by the Engineer-In-Charge.

Clause - 11 : The contractor shall execute the whole and every part of the work in the most substantial and workman like manner and both as regards materials and otherwise in every respect in strict accordance with the specifications. The contractor shall also conform exactly, fully and faithfully to the designs, drawing and instructions in writing in respect of the work as signed by the Engineer-In-Charge and the contractor shall be furnished free of charge all such designs, drawings and instructions as not included in the latest C.P.W.D. specifications or any other printed publication or General specifications referred to elsewhere in the contract Matters not covered by the specification given in this contract as a whole shall be covered by relevant and latest India Standard Codes. If such code on a particular subject has not been framed then relevant British standard code shall be followed. If such codes for a particular subject have not been framed, the decision of the Engineer-In-Charge will be final and binding.

Clause - 12 : The Engineer-In-Charge shall have power to make any alterations or omissions from, additions to or substitutions for, the original specification drawings, designs and instruction that may appear to him to be necessary during the progress of the work and the contractor shall carry out the work in accordance with any instructions which, may be given to him in writing signed by the Engineer-In-Charge and such alterations, omissions, additions, or substitutions shall not invalidate the contract and any altered, additional or substituted work which the contractor may be directed to do in the manner above specified as part of the work shall be carried out by the contractor on the same conditions in all respects on which he agreed to do the main work. The time for completion of the work shall be extended in the proportion that altered, additional and substituted work bears to the original contract work, and the certificate of Engineer-In-Charge shall be conclusive as to such proportion over and above this, a further period to the extent of 25% of the time so extended shall be allowed to the contractor. The rates for such additional, the altered or substituted work under this clause shall be worked out in accordance with the following provisions in their respective order.

(i) If the rates for additional, altered or substituted work are specified in the contract for the work, the contractor is bound to carryout the additional, altered or substituted work at the same rates as are specified in the contract for the work.

Contractor

For & on behalf of SJVN Ltd.

(ii) If the rates for the additional, altered or substituted work are not specifically provided in the

contract for the work, the rates will be derived from the rates for a similar class of work as are specified in the contract for the work.

(iii) If the altered, additional or substituted work includes any work for which no rate is specified in the contract and cannot be derived from similar class of work in the contract, then such work shall be carried out at the rates entered in SJVN schedule of rate, Himachal Pradesh schedule of rates, Delhi schedule of rates based on which the estimate has been prepared minus/plus percentage which the total tendered amount bears to the estimated cost of the entire work put to tender.

(iv) If the rates for the altered, additional or substituted work cannot be determined in the manner specified in clause (i) to (iii) above, then the rates for such work shall be worked out on the basis of the schedule of rates of the district specified above minus/plus the percentage which the total tendered amount bears to the estimated cost of the entire work put to tender. Provided always that if the rate for a particular part or parts of the item is not in schedule of rates, the rate for such part or parts will be determined by the Engineer-In-Charge on the basis of prevailing market rates when the work was done.

(v) If the rates for the altered, additional or substituted work can not be determined in the manner specified in sub/clause (i) to (iv) above, then the contractor shall within 7 days of the date of receipt of order to carry out the work, inform the Engineer-In-Charge of the rate which it is his intention to charge for such class of work, supported by analysis of the rate or rates claimed and the Engineer-In-Charge shall determine the rate or rates on the basis or prevailing market rates, and pay the contractor accordingly. However, the Engineer-In-Charge by notice in writing will be at liberty to cancel his order to carryout such class of work and arrange to carry it out in such manner as he may consider advisable. But under no circumstances, the contractor shall suspend the work on the plea of non-settlement of the rates of items falling under this clause.

(vi) Except in case of items relating to foundation, provision contained in sub/clause (i) to (

v) Above shall not apply to contract or substituted items as individually exceed the percentage set out in the tender documents (referred to here below as 'deviation limit' ; as mentioned under clause-12 A hereof), subject to the following restrictions:

(a) The deviation limit referred to above is the net effect (algebraically sum) of all additions and deductions ordered.

(b) In no case shall the additions/deductions (arithmetical sum) exceed twice the deviation limit.

(c) The deviations ordered on items of any individual trade included in the contract shall not exceed plus/minus 50% of the value of that trade in the contract as a whole or half the deviation limit, whichever is less.

(d) The value of additions of items of any individual trade not already included in the contract shall not exceed 10% of the deviation limit.

Contractor

For & on behalf of SJVN Ltd.

Note : Individual trade means the trade sections into which a schedule of quantities annexed to the agreement has been divided or in the absence of any such division, the individual sections of the Himachal Pradesh Public Work Department schedule of rates specified above, such as excavation and earth work, concrete, wood work and joinery etc.

The rate of any such work except the items relating to foundations which in excess of the deviation limit shall be determined in accordance with the provisions contained in clause-12 (A).

For the purpose of operation of Clause-12 (A) the following work shall be treated as work relating to foundations.

- (a) For building, plinth level or 1.2 metre (4 feet) above ground level which ever is lower excluding items of flooring and D.P.C. but including base concrete below the floors.
- (b) For abutments, piers, retaining walls of culverts and bridges, walls of water reservoirs the bed or floor level.
- (c) For retaining walls where floor level is not determined 1.2 metres above the average ground level or bed level.
- (d) For roads all items of excavation and filling including treatment of sub-base and soling work.
- (e) For water supply lines, sewer lines, under ground storm water drains and similar works all items of work below ground level except items of pipe work, proper masonry work.
- (f) For open storm water drains, all items of work except lining of drains.

Clause - 12 A : The Unit Rate entered in the bill of quantities for the individual items shall apply for the quantities or work increased or decreased by not more than twenty percent (20%) for each item. Should the quantity of work actually executed under any item except the items relating to foundation work exceed by more than twenty percent (20%) or the quantity provided in the Bill of quantities for that item, the rate for such excess over 120% quantity under the item may be revised in accordance with the procedure indicated under Clause-12 hereof. In such an event, the contractor shall, with in seven (7) days from the receipt of order, claim revision of the rates supported by proper analysis.

Should the quantity of work actually executed under any item, get reduced by more than 20% of the quantity provided in the Bill of quantities for that item, the rate for that item may be revised in accordance with the procedure indicated in Clause-12 hereof.

The Engineer-In-Charge shall, however, be at liberty to cancel his order to carry out such increased quantities of work by giving notice in writing to the contractor and arrange to carry it out in such manner as he may consider appropriate. But under no circumstances the contractor shall suspend the work on the plea of non-settlement of rates of items falling under this clause.

Clause - 13 : If at any time after the commencement of the work the SJVN shall for any reason, whatsoever, not require the whole thereof as specified in the tender to be carried out, the Engineer-In-Charge shall give notice, in writing of the fact to the contractor who shall have no claim to any payment of compensation whatsoever on account of any profit or advantage which he might have derived from the execution of the work in full, but which he

Contractor

For & on behalf of SJVN Ltd.

did not derive in consequence of the full amount of the work no having been carried out, neither shall he have any claim for compensation by reason of any alterations having been made in the original specifications, drawing, designs and instructions which shall involve any curtailment of the work as originally contemplated.

Provided that the contractor shall be paid the charges on the cartage only of materials actually and bonafide brought to the site of the work by the contractor and rendered surplus as a result of the abandonment or curtailment of the work or any portion thereof and then taken back by the contractor provided however that the Engineer-In-Charge shall have in all such cases the option of taking over all or any such materials at their purchase price or at local current rates which ever may be less. In the case of such items having been issued from SJVN stores, supervision charges and storage shall be refunded in addition to the issue rate of materials.

Clause - 14 : If it shall appear to the Engineer-In-Charge or his subordinate in charge of the work, that any work has been executed with unsound, imperfect or unskillful workmanship or with materials of any inferior description or that any materials or articles provided by him for the description of the work are unsound or of a quality inferior to that contracted for or otherwise not in accordance with the contract, the contractor shall, on demand in writing which shall be made with in six months of the completion of the work from the Engineer-In-Charge specifying the work, materials or articles complained notwithstanding that the same may have been passed, certified and paid for, forthwith rectify or remove and reconstruct the work so specified in whole or in part, as the case may require or as the case may be, remove the materials or articles so specified and provide other proper and suitable materials or articles at his own proper charge and cost and in the event of his failing to do so within a period to be specified by the Engineer-In-Charge in his demand aforesaid, than the contractor shall be liable to pay compensation at the rate of one percent on the tendered amount for everyday not exceeding ten days while his failure to do so shall continue and in the case of any such failure, the Engineer-In-Charge may rectify or remove and re-execute the work or remove and replace with others the materials or articles so complained of as the case may be, at the risk and expense in all respects of the contractor.

Clause - 15 : All work under or in course of execution or executed in pursuance of the contract shall at all times be open to the inspection and supervision of the Engineer-In-Charge and his authorised subordinates and the contractor shall at all times during the usual working hours and at all other times at which reasonable notice of the intention of the Engineer-In-Charge or his subordinate to visit the works shall have been given to the contractors, either himself be present to receive orders and instructions, or have reasonable agent duly accredited, in writing present for that purpose. Order given to the contractor's agent shall be considered to have the same force as if they had been given to the contractor himself.

Clause - 16 : The contractor shall give not less than seven days notice in writing to the Engineer-In-Charge or his subordinate-In-Charge of the work before covering up or otherwise placing beyond the reach of measurement any work in order that the same may be measured: and correct dimensions there of be taken before the same is so covered up or placed beyond the reach or measurement and shall not cover up and place beyond the

Contractor

For & on behalf of SJVN Ltd.

reach of measurement any work without the consent in writing to the Engineer-In-Charge or his subordinate-In-Charge of the work who shall within the aforesaid period of seven days, inspect the work and if any work shall be covered up or placed beyond the reach of measurement without such notice having been given or the Engineer-In-Charge's consent being obtained, the same shall be uncovered at the contractor's expenses, or in default thereof no payment or allowance shall be made for such work or the materials with which the same was executed.

Clause - 17 : If the contractor or his work people or servants shall break, deface injure or destroy any part of the building in which they may be working or any building, road curve, fence, enclosure, water pipe, cable, drainage electric or telephone post or wires, trees, grass or land or cultivated ground continuous to premises on which the work or any part of it being executed or if any damage shall happen to the work while in progress, from any cause whatever or if any defect, shrinkage or other faults appear in the work other than road work costing Rs. 20, 000 and below after a certificate final or otherwise of its completion shall have been given by the Engineer-In-Charge as aforesaid arising out of defective or improper materials or workmanship, the contractor shall have upon a receipt of a notice in writing in that behalf make the same good at his own expense, or in default the Engineer-In-Charge, may cause the same to be made good by other workman and deduct the expenses from any sums that may then or at any time thereafter may become due to the contractor or from his security deposit, except from the portion pertaining to asphaltic work, which is governed, by sub-para (ii) of clause 35 or the proceeds of sale thereof or a sufficient portion thereof. The security deposit of then contractor except the portion pertaining to asphaltic work, which is governed, by sub-para (ii) of clause 35 shall not be refunded before the expiry of 6 months (three months in the case of any work other than road work costing Rs. 20, 000 and below) after the issue of the certificate final or otherwise of completion of work or till the final bill has been prepared and passed, whichever is later, provided that in the case of road work if in the opinion of the Engineer-In-Charge Half of the security deposit is sufficient to meet all the liabilities of the contractor under this contract half of the security deposit will be refundable after 3 months and the remaining half after 6 months of the issue of the said certificate of completion or after the final bill has been prepare and passed, whichever is later.

Clause - 18 : The contractor shall supply and provide at his own cost all material (except such special materials if any, as may in accordance with the contract be supplied from the Engineer-In-Charges stores) plant, tools, appliances, letters, cordage, tackle, scaffolding and temporary works requisite or proper for the proper executing of the work, whether original, altered or substituted and whether included in the specification or the documents forming part of the contract or referred in these conditions or not, or which may be necessary for the purpose of satisfying or complying with the requirements or the Engineer-In-Charge as to any matter as to which he is entitled to require together with carriage therefore to and from the work. The contractor shall also supply without charge the requisite number of persons with the means and materials necessary for the purpose of setting out works and counting, weighing and assisting of the measurement or examination at any time and from time to time of the work or materials, Failing his so doing, the same may be provided by the Engineer-In-Charge at the expense of the contractor and the expenses may be deducted from any money due to the contractor, under the contract and/or from his security deposit or the proceeds of sale thereof or a sufficient portion thereof.

Contractor

For & on behalf of SJVN Ltd.

Clause - 18 A : In every case in which by virtue of the provision of section 12, sub-section (1) of the workman's compensation Act, 1923, SJVN is obliged to pay compensation to a workman employed by the contractor in execution of the work. SJVN will recover from the contractor the amount of compensation so paid; and, without prejudice to the rights of the SJVN under section 12, sub-section (2) of the said Act, SJVN shall be at liberty to recover such amount or any part thereof by deducting if from the security deposit or from any sum due by SJVN to the contractor whether under this contract or otherwise. SJVN shall not be bound to contest any claim made against if under section 12, sub-section (1) of the said Act, except on the written request of the contractor and upon his giving to SJVN full security for all costs for which SJVN might become liable in consequence of contesting such claim.

Clause - 19 : No labourers below the age of fourteen years shall be employed on the work.

19 (a) In respect of all labour directly or indirectly employed on the work for performance of the contractor's part of the agreement the contractor shall comply with or cause to be complied with the SJVN Limited, Contractors Labour Regulations made by the Government from time to time in regard to payment of wages, wage period, deduction from wages, recovery of wages not paid and deductions unauthorisedly made, maintenance of wage books or wage slips, publication of scale of wages and other terms of employment, inspection and submission of periodical returns and all other matters of like nature.

(b) The Engineer-In-Charge shall have the right to deduct, from the money due to the contractor any sum required or estimated to be required for making good the loss suffered by a worker or workers due to reasons of non-fulfillment of the conditions of the contract for the benefit of the workers, non-payment of wages or of deductions made from his or their wages which are not justified by their terms of the contract or non observance of regulations.

(c) Under the provision of the minimum wages Act. 1948 and Himachal Pradesh Government Minimum Wages Rules, 1959, and any subsequent amendment the contractor is bound to allow or cause to be allowed to the labourers directly or indirectly employed in the works, one day's rest for six days continuous work and pay wages at the same rate as for duty. In the event of default the Engineer-In-Charge shall have the right to deduct the sum or sums not paid on account of wages for weekly holidays to any labourers and pay the same to the persons entitled there to from any money due to the contractor.

(d) Vis-a-Vis the SJVN the contractor shall be primarily liable to all payment to be made under and for the observance of regulations aforesaid without prejudice to his right to claim indemnity from his sub-contractors.

(e) The regulations aforesaid shall be deemed to be part of this contract and any breach there of shall be deemed to be a breach of this contract.

(f) The contractor shall ensure that no amount by way of commission or otherwise is deducted or recovered by the Jamadaras from the wage of the workmen.

Clause - 19 A : No female labourers shall be employed within the limits of cantonment.

Contractor

For & on behalf of SJVN Ltd.

Clause - 19 B : In respect of all labour directly or indirectly employed in the work for the performance of the contractor's part of this agreement, the contractor shall at his own expense arrange for the safety provisions as per safety code framed from time to time and shall at his own expense provide for all facilities in connection therewith. In case the contractor fails to make arrangement and provide necessary facilities as aforesaid he shall be liable to pay a penalty as per regulations for each default and in addition the Engineer-In-Charge shall be at liberty to make arrangement and provide facilities as aforesaid and recover the costs incurred in that behalf from the contractor.

Clause - 19 C : The contractor shall submit, by the 4th and 19th of every month to the Engineer-In-Charge, a true statement showing in respect of the second half of the preceding month and the first half of the current month, respectively (1) the number of labours employed by him on work, (2) their working hours, (3) wages paid to them, (4) the accidents that occurred during the said fortnight showing the circumstances under which they happened and the extent of damage and injury caused by them and (5) the number of female workers who have been allowed maternity benefit according to clause 19F and the amount paid to them, failing which the contractor shall be to pay to SJVN a sum not exceeding Rs. 50 for each default of materially incorrect statement. The decision of the Engineer in-charge shall be final in deducting from any bill due to contractor, the amount levied as fine.

Clause - 19 D : In respect of all labour directly or indirectly employed in the work for the performance of contractor's part of this agreement the contractor shall comply with or cause to be complied with all the rules framed by SJVN from time to time for the protection of health and sanitary arrangement for workers employed by the SJVN and its contractors.

Clause - 19 E : Leave and pay during leave shall be regulated as follows:

1. Leave : (i) In case of delivery, maternity leave not exceeding 8 weeks, 4 weeks upto and including the day of delivery and 4 weeks following that day.
(ii) In the case of miscarriage upto 3 weeks from the date of miscarriage.

2. Pay (i) In case of delivery leave pay during maternity leave will be at the rate of the woman's average daily earnings, calculated on the total wages earned on the days when full time work was done during a period of 3 months immediately proceeding the date on which she gives notice that she expects to be confined or at the rate of minimum daily wages whichever is greater.

(ii) In case of miscarriage leave pay at the rate of average daily earnings calculated on the total wages earned on the days when full time work was done during a period of 3 months immediately preceding the date of such miscarriage.

3. Conditions for the grant of maternity leave : No maternity leave benefit shall be admissible to a woman unless she has been employed for a total period of not less than 6 months immediately preceding the date on which she proceeds on leave.

The contractor shall maintain a register of maternity benefit in the prescribed form as shown below and the same shall be kept at the place of work.

Contractor

For & on behalf of SJVN Ltd.

register of maternity benefit (Clause - 19 F)

Name and address of the contractor (s).....

Name and location of the work.....

Name of Employee	Father/Husband's name	Nature of employment	Period of actual appointment.	Date of which
------------------	-----------------------	----------------------	-------------------------------	---------------

notice of confinement

given.

1.	2.	3.	4.	5.
----	----	----	----	----

Date of delivery/
miscarriage

Date on which maternity leave commenced and ended.

In case of deliver

In case of miscarriage

Commenced Ended

Commenced

Ended.

6.	7.	8.	9.	10.
----	----	----	----	-----

Leave pay paid to the employee

Remarks

In case of delivery

In case of miscarriage

Rate of Amount paid

Rate of leave Pay

Amount Paid

leave pay

11.	12.	13.	14.	15.
-----	-----	-----	-----	-----

Specimen from the register regarding maternity benefit admissible to the contractor's labour.

1. Name of work.
2. Name of contractor.
3. Designation.
4. Date of appointment.
5. Name of woman and her husband's name.
6. Dates with months and years in which she is employed.
7. Date of discharge/dismissal, if any.
8. Date of production of certificate in respect of pregnancy.
9. Date on which the woman informs about the expected delivery.
10. Date of delivery/miscarriage/death.
11. Date of production of certificate in respect of delivery/miscarriage.
12. Date with the amount of maternity/death benefit paid in advance of expected delivery.
13. Date with the amount of subsequent payment of maternity benefit.
14. Name of the person nominated by the woman to receive the payment of the maternity benefit after her death.

Contractor

For & on behalf of SJVN Ltd.

15. If woman dies, the date of her death names of the person to whom maternity benefit amount was paid.
16. Signature of the contractor authenticating entries in register.
17. Remarks columns for the use of the Inspecting Officer.

Clause - 19 F : In the event of the contractor (s) committing a default or breach of any of the provisions of the H.P. Govt./Central Govt./SJVN Limited. Contractor's Labour Regulations and Model Rules for the protection of Health and sanitary arrangements for the workers as amended from time to time or furnishing any information or submitting or filling any statement under the provisions, of the above Regulations and Rules. Which is materially incorrect, he/they shall without prejudice to any other liability pay to SJVN a sum not exceeding Rs. 50 for every default, breach or furnishing, making, submitting, filing such materially incorrect statements and in the event of the contractor (s) defaulting consciously in this respect, the penalty may be enhanced to Rs. 50 per day of default subject to a maximum of 5 percent of the estimated cost of the work put to tender. The decision of the Engineer-In-Charge shall be final and binding on the parties. Should it appear to the Engineer-In-Charge that contractor (s) is/are not properly observing and complying with the Model Rules for the protection of health and sanitary arrangements for work people employed by the contractor(s) (thereinafter referred as the said rules) the Engineer-In-Charge shall have power to give notice in writing to the contractor(s) requiring that the said rules be complied with and the amenities prescribed therein be provided to the work people within a reasonable time to be specified in the notice, if the contractor(s) shall fail within the period specified in the notice to comply with and observe the said rules and to provide the amenities to the work people as aforesaid, the Engineer-In-Charge shall have the power to provide the amenities here in before mentioned at the cost of the contractor(s) The contractor(s) shall erect, make and maintain at his/their own expense and to approved standards, all necessary huts and sanitary arrangements required for his/their work people on the site in connection with the execution of the works and if the same shall not have been erected or constructed, according to approved standards, the Engineer-In-Charge shall have power to give notice in writing to the contractor(s) requiring that the said huts and sanitary arrangements be remodeled and/or reconstructed according to approved standards and if the contractor shall fail to remodel or reconstruct such huts and sanitary arrangement according to approved standards within the period specified in the notice, the Engineer-In-Charge shall have the power to remodel or reconstruct such huts and sanitary arrangements according to approved standards at the cost of contractor (s).

Clause - 19 G : The contractor (s) shall at his/their own cost provide his/their labour with sufficient number of huts (hereinafter referred to as the camp) of the following specification on suitable plot of land to be approved by the Engineer-In-Charge.

1. (a) The minimum height of each hut at the eye level shall be 2.1 m and the floor area to be provided, will be at the rate of 2.8 sq meter for each member of the workers family staying with the laborer.

(b) The contractor (s) shall in addition construct suitable cooking places having minimum area of 1.8 x 1.5 m adjacent to the hut for each family.

Contractor

For & on behalf of SJVN Ltd.

(c) The contractor (s) shall also construct temporary latrines and urinals for the labourers on the scale of not less than four per each one hundred of the total strength, separate latrines and urinals being provided for women.

(d) The contractor shall construct sufficient number of bathing and washing places, one unit for every 25 persons residing in the camp. The bathing and washing places shall be suitably screened.

2 (a) All the huts shall have walls of sun-dried or burnt bricks laid in mud mortar or other suitable local materials as may be approved by the Engineer-In-Charge. In case of sun dried bricks the walls should be plastered with mud gobri on both sides.

The floor may be katcha but plastered with mud gobri and shall be at least 15 cm above the surrounding ground. The roofs shall be laid with thatched or any other materials as may be approved by the Engineer-In-Charge and the contractor shall ensure that throughout the period of their occupation the roofs remain water tight.

(b) The contractor (s) shall provide each hut with proper ventilation.

(c) All doors, windows and ventilators shall be provided with suitable leaves for security purposes.

(d) There shall be kept an open space of at least 7.2 m between the rows of huts which maybe reduced to 6 meters according to the availability of site with the approval of the Engineer-In-Charge, back to back construction will be allowed.

3. Water supply: The contractor(s) shall provide adequate supply of water for the use of labourers. The provision shall not be less than 2 gallons of pure and wholesome water per head per day for drinking purpose and 3 gallons of clean water per head per day for bathing and washing purpose. Where piped water supply is available, supply shall be at stand posts and masonry, shall be provided. The contractor (s) shall also at his/their own cost makes arrangement for laying pipe lines for water supply to his/their labour camp from the existing mains, wherever available and shall pay all fees and charges therefore.

4. The site selected for the camp shall be high ground, removed from jungle.

5. Disposal of excreta : The contractor (s) shall make necessary arrangements for the disposal of excreta from the latrines by trenching or incineration which shall be according to the requirements laid down by the local health authorities. If trenching or incineration is not allowed the contractor (s) shall make arrangements for the removal of the excreta through the Municipal Committee/Authority and inform it about the number of labours employed so that arrangements may be made by such committee/authority for the removal of the excreta. All charges on this account shall be borne by the contractor and paid directly by him to the Municipal Corporation. Then contractor shall provide one sweeper for every 8 seats, in case of dry system.

Contractor

For & on behalf of SJVN Ltd.

6. Drainage : The contractor (s) shall provide efficient arrangement for draining away salvage water so as to keep the camp neat and tidy.

7. The contractor (s) shall make necessary arrangements for keeping the camp area sufficiently lighted to avoid accidents to the workers.

8. Sanitation : The contractor (s) shall make arrangements for conservancy and sanitation in the labour camps according to the rules of the local public health and medical authorities.

Clause - 19 H : The Engineer-In-Charge may require the contractor to dismiss or remove from the site of work any person or persons in the contractors employment on the work who may be incompetent or misconduct himself and the contractor shall forthwith comply with such requirement.

Clause - 20 : The contractor shall comply with all the provisions of the Minimum Wages Act. 1948 and rules framed there under and labour laws affecting contract labour that may be brought into force from time to time.

Clause - 21 : The contractor shall not assign or sublet the entire work or part thereof without the written approval of the Engineer-In-Charge. And if the contractor shall assign or sublet his contract or attempt to do so or become insolvent or commence any insolvency proceedings or make any composition with his creditors or attempt to do so or if any bribe, gratuity, gift, loan, perquisite, reward or advantage pecuniary or otherwise, shall either directly or indirectly, be given promised or offered by the contractor or any of his servants or agent to any public officer or person in the employment of SJVN in any way relating to his office or any way directly or indirectly interested in the contract, the Engineer-In-Charge on behalf of the corporation shall have power to adopt any of the courses specified in clause 3 as he may deem best suited in the interest of the corporation and in the event of any of these courses being adopted; the consequences specified in the said clause 3 shall follow.

Clause - 22 : Any sum(s) payable by way of compensation under any of these conditions shall be considered as reasonable compensation (to be applied to the use of SJVN) without reference to the actual loss or damage sustained, and whether or not any damage shall have been sustained.

Clause - 23 : Where the contractor is a partnership firm the previous approval in writing of the Engineer-In-Charge shall be obtained before any change is made in the constitution of the firm. Where the contractor is an individual or a Hindu undivided family business concern such approval as aforesaid shall likewise be obtained before the contractor enters into any partnership agreement where under the partners of partnership firm would have the right to carry out the work undertaken by the contractor. If previous approval as aforesaid is not obtained, the contract shall be deemed to have been assigned in contravention of clause-21 thereof and the same action may be taken and the same consequences shall ensure as provided in the said clause.

Contractor

For & on behalf of SJVN Ltd.

Clause - 24 : All works to be executed under the contract shall be executed under the direction and subject to the approval in all respects of the Engineer-In-Charge who shall be entitled to direct at what point or points and in what manner they are to be commenced and from time to time carried on.

Clause - 25 : Except where otherwise provided in the contract all questions and disputes relating to the meaning of the specifications, designs, drawings and instructions hereinbefore mentioned and as to the quality of workmanship of materials used on the work as to any other questions, claim, right, matter or thing whatsoever, in any way arising out of or relating to the contract designs, drawings, specifications, estimates, instructions, orders or these conditions otherwise concerning the work or the execution or failure to execute the same whether arising during the progress of the work or after the completion or abandonment thereof, shall be referred to the single arbitrator of the person appointed by the Head of Project, NJHPS SJVN Ltd. It will be no objection to any such appointment that the arbitrator so appointed is a Government/SJVN servant, that he had to deal with the matters to which the contract relates, and that in the course of his duties as Government/SJVN servant, he had expressed views on any or any of the matters in dispute or difference. The arbitrator to whom the matter is originally referred being transferred or vacating his office or being unable to act for any reason, the Head of Project, NJHPS SJVN Ltd. at the time of such transfer, vacation of office or inability to act shall appoint another person to act as arbitrator in accordance with the terms of the contract. Such person shall be entitled to proceed with the reference from the stage at which it was left by his predecessor. It is also a term of this contract that no person other than a person appointed by the Head of Project, NJHPS SJVN Ltd. should act as arbitrator and if for any reason that is not possible, the matter is not to be referred to arbitration at all. In all case where the amount of the claim in dispute is Rs. 50, 000 (Rupees fifty thousand) and above, the arbitrator shall give reasons for the award.

Subject as aforesaid the provision of the Arbitration & Reconciliation Act. 1996, or any statutory modification or re-enactment thereof and the rules made there under and for the time being in force shall apply to the arbitration proceeding under this clause.

It is also a term of the contract that the party invoking arbitration shall specify the disputes to be referred to arbitration under this clause together with the amount of amounts claimed in respect of each such dispute.

It is also a term of the contract that if the contractor (s) does/do not make any demand for arbitration in respect of any claim in writing within 90 days of receiving the intimation from the SJVN and the bill is ready for payment, the claim of the contractor (s) will be deemed to have waived and absolutely barred and the SJVN shall be discharged and released of all liabilities under the contract in respect of these claims.

The arbitrator (s) may from time to time with consent of the parties extend the time for making and publishing the award.

Clause - 26 : The contractor shall fully indemnify SJVN against any action, claim or proceeding relating to infringement or use of any patent or design or any alleged patent or design rights and shall pay any royalties which may be payable in respect of any article or

Contractor

For & on behalf of SJVN Ltd.

part thereof included in the contract. In the event of any claims, made under or action brought against SJVN in respect of any such matters as the aforesaid, the contractor shall be immediately notified thereof and the contractor shall be at liberty, at his own expenses, to settle any dispute or to conduct any litigation that may arise there from provided that the contractor shall not be liable to indemnify the SJVN if the infringement of the patent or design or any alleged patent or design right is the direct result of an order passed by the Engineer-In-Charge in this behalf.

Clause - 27 : When the estimate on which a tender is made includes lump-sum in respect of part of the works, the contractor shall be entitled to payment in respect of the items of work involved or the part of the work in question at the same rates, as are payable under this contract For items not susceptible of measurement the Engineer-In-Charge, may at his discretion pay the lump-sum amount entered in the estimate and the certificate in writing of the Engineer-In-Charge shall be final and conclusive against the contractor with regard to any sum of sums Payable to him under the provision of this clause.

Clause - 28 :

ACTION WHERE NO SPECIFICATION GIVEN

In the case of any work or item of work for which there are no specification indicated in the tender document relating to technical specifications drawings appended to the tender, such work of items of work shall be carried out in all respects in accordance with the instructions and requirements prescribed by the Engineer-In-Charge. The rates for such work, shall be determined by the Engineer-In-Charge which shall be final and binding on the contractor.

Clause - 29 : 1) Whenever any claim, against the contractor for the payment of a sum or money arises out of or under the contract, SJVN shall be entitled to recover such sum by appropriating, in part or whole, the security deposit of the contractor and to sell any Government promissory notes etc. forming the whole or part of such security. In the event of the security being insufficient or if no security has been taken from the contractor, then the balance or the total sum recoverable, as the case may be, shall be deducted from any sum then due or which at any time thereafter may become due from the contractor under this or any other contract with SJVN. Should this sum be not sufficient to cover the full amount recoverable, the contractor shall pay to SJVN on demand the balance remaining due.

(2) SJVN shall have the right to cause an audit and technical examination of the works and the final bills of the contractor including all supporting vouchers, abstract etc. to be made after payment of the final bill and if as a result of such audit and technical examination any

sum is found to have been over paid in respect of any work done by the contractor under the contract or any work claimed by him to have been done by him under the contract and found not to have been executed, the contractor shall be liable to refund the amount of over payment and it shall be lawful for SJVN to recover the same from him in the manner prescribed in sub clause (1) or this clause or in other manner legally permissible, and if its is found that the contractor was paid less than what was due to him under the contract in

Contractor

For & on behalf of SJVN Ltd.

respect of any work executed by him under it, the amount of such under payment shall be duly paid by SJVN to the contractor.

Provided that SJVN shall not be entitled to recover any sum overpaid, nor the contractor shall be entitled to payment any sum paid short where such payment has been agreed upon between the SJVN on the one hand and the contractor on the other under any term of the contract permitted payment for work after assessment by the Engineer-In-Charge.

The work (whether fully executed or not) and all material machine, tools and plants scaffolding, temporary buildings and other things connected therewith shall be at the risk of the contractor until the work has been delivered to the Engineer-In-Charge and certificate from him to that effect obtained, in the event of the work or any material property brought to the site for incorporation in the work being damaged or destroyed in consequence of hostilities or war like operations the contractor shall, when ordered in writing by the Engineer-In-Charge remove any debris from the site, collect and properly stack or remove in store all serviceable material salvage from the damage work and shall be paid at the contract rates in accordance with the provision of this agreement for the work clearing the site of debris, stacking or removal of serviceable material and for the reconstruction of all work ordered by the Engineer-In-Charge, such payments being in addition to compensation upto the value of the work originally executed before being damaged or destroyed and not paid for. In case of work damaged or destroyed but not already measured and paid for the compensation shall be assessed by the Engineer-In-Charge. The contractor shall be paid for the damage destruction suffered and for restoring the material at the rates, based on the analysis of rates, tendered for in accordance with the provision of this agreement. The certificate of the Engineer-In-Charge regarding the quality of material and the purpose for which they were collected shall be final and binding on all parties to this contract.

Provided always that no compensation shall be payable for any losses in consequence of hostilities' or war like operation (a) unless the contractor had taken all such precautions against air raids as deemed necessary by the air officer or the Engineer-In-Charge (b) for any material etc. not on the site of the work or for any tools, plant, machinery, scaffoldings, temporary buildings and other things not intended for the work.

In the case of contractor having to carry out reconstructions as aforesaid he shall be allowed such extensions of time for its completion as is considered reasonable by the Engineer-In-Charge.

Any sum of money due and payable to the contractor including the security deposit returnable to him under this contract may be appropriated by the SJVN and set off against any claim of the SJVN for the payment of sum of money arising out of or under any other contract made by the contractor with the SJVN.

Clause - 30 : The contractor shall not employ coal mining or controlled area labour falling under any category whatsoever on or in connection with the work or recruit labour from area with a radius of 20 miles of the controlled area. Subject as above the contractor shall employ imported labour only i. e. depot imported labour imported by contractor from areas from which import is permitted.

Where ceiling price for imported labour has been fixed by state or Regional Labour Committee not more than that ceiling prices shall be paid to the labour by the contractor.

Contractor

For & on behalf of SJVN Ltd.

The contractor shall immediately remove any labourer who may be pointed out by the Engineer-In-Charge as being a local mining or controlled area labourer. Failure to do so shall render the contractor liable to pay to SJVN a sum calculated at the rate of Rs. 10 Per day for labour. The certificate of the Engineer-In-Charge about the number of coal mining or controlled area labour and the number of days for which they worked shall be final and binding upon all parties to the contract.

It is declared and agreed between the parties that aforesaid stipulation in this clause of one in which the public are interested within the meaning of the execution of section 74 of the Indian Contract Act, 1872

Explanation : controlled Area means the following areas :

Bihar : District of Manbhum, Hazaribagh, Jamtra Sub-Division of SantalParganas.

West Bangal : District of Bankura, Birbhum, Burdwan.

Madhya Pradesh : District of Bilaspur.

Any other area which may be declared as 'Controlled Area' by or with the approval of the Central Government.

Clause - 31 & 31 (a) for water charges :

Water required for the execution of work may be supplied to the contractor(s) at the direction of the Engineer-In-Charge on the following conditions:

Payment by the contractor (s) @ 1.5% of the total cost of the entire work done under the contract.

The contractor (s) shall make his/their own arrangement for water connection and laying of pipe line from existing main or source or supply It would be clearly understood that SJVN do not guarantee to maintain the uninterrupted water supply and it will be incumbent on the contractor (s) to make alternative arrangements for water on his/their own cost in the event of any temporary break down in the SJVN water mains so that progress of his/their work is not held up for want of water. No claim of damage or required water charges will be entertained on account of such breakdown.

Clause - 31 (b) electricity charges :

The contractor shall make his own arrangements for power supply and charges payable for the same shall be paid by the contractor to the concerned authorities.

Clause - 32 : (i) Where there is no piped water supply arrangement and the water is taken by the contractor from the wells or hand pumps, constructed by the Government /SJVN, no charge shall be recovered from the contractor on that account. The contractor shall however draw water at such hours of the day that it does not interfere with the normal use for which the hand pumps and wells are intended. He will also be responsible for all damage and abnormal repairs arising out of his use, the cost of which shall be recoverable from him. The Engineer-In-Charge shall be the final authority to determine the cost recoverable from the contractor on this account.

Contractor

For & on behalf of SJVN Ltd.

(ii) The contractor shall be allowed to construct temporary wells in SJVN land for taking water for construction purpose only after he has got permission of the Engineer-In-Charge in writing. No charge shall be recovered from the contractor on this account, but the contractor shall be required to provide necessary safety arrangement to avoid any accidents or damage to adjacent building, roads and service lines. He shall be responsible for any accidents or damage cause due to construction and subsequent maintenance of the walls and shall restore the ground to its original condition after the wells are dismantled on completion of work.

Clause - 33 : Notwithstanding anything to the contrary in any or all the clause of this contract, where any material for the execution of the contract are procured with the assistance of SJVN either by issue from SJVN stocks or purchase made under orders or permits or licenses issued by SJVN, the contractor shall hold the said material economically and solely for the purpose of the contract and not dispose off them without the permission on the SJVN and return, if required by the Engineer-In-Charge, all surplus material that may be left with him after the completion of the contract or at its termination for any reason whatsoever on being paid for or credited such prices as the Engineer-In-Charge shall determine, having due regard to the conditions of the materials. The price allowed to the contractor however shall not exceed the amount charged to him excluding the storage charges, if any. The decision of the Engineer-In-Charge shall be final and conclusive. In the event of breach of the aforesaid condition, the contractor shall in addition to throwing himself open to action for contravention of the terms of the licences or permit and/or for criminal breach of trust, be liable to SJVN for all moneys, advantages or profits resulting or which in the usual course would have resulted to him by reason of such breach.

Clause - 34 : The contractor shall be responsible to return the plant and machinery in the condition in which it was handed over to him and he shall be responsible for all damage caused to the said plant and machinery at the site of work or elsewhere during the operation or during transit including damage to or loss of parts and for all losses due to his failure and return the same soon after the completion of the work for which it was issued. The Engineer-In-Charge shall be the sole authority to determine the liability of the contractor and its extent in this regard and his decision shall be final and binding on the contractor.

Clause - 35 : (i) The contractor shall collect the total quantity of tar or bitumen required for the work as per standard formula, before the process of printing is started and shall hypothecate it to the Engineer-In-Charge. If any bitumen or tar remains unused on completion of the work on account of lesser use of materials, in actual execution for reasons other than authorised charges of specification and abandonment of portion of work, a corresponding deduction equivalent to the cost of unused materials as determined by the Engineer-In-Charge shall be made and the materials returned to the contractors. Although the materials are hypothecated to SJVN, the contractor undertakes the responsibility for their proper and safe custody and protection against all risk. The materials shall not be removed from site of work without the consent of Engineer-In-Charge.

(ii) The contractor shall be responsible for rectifying defect noticed within one year from the date of completion of the work and the portion of the security deposit relating to asphaltic work shall be refunded after the expiry of this period.

Contractor

For & on behalf of SJVN Ltd.

Clause - 36 : The contractor shall employ the following technical staff during the execution of this work.

1. Two graduate Engineer when cost of work to be executed is Rs. 4.00 crores and proportionate increase in number with increase in quantum of work.

2. The technical staff should be available at site, whenever required by Engineer-In-Charge to take instructions.

In case the contractor fails to employ the technical staff as aforesaid, he shall be payable to pay a sum of Rs. 5,000/- (Rupees Five thousand) for each month of default.

Clause - 37 : Sale tax or any other tax on materials in respect of this contract shall be payable by contractor, and SJVN shall not entertain any claim, whatsoever, in this respect.

Clause - 38 : In pursuance to or under any law, such notification order, any royalty, cost fee or the like becomes payable by the SJVN and does at any time become payable by the contractor, to H. P. Government Local authorities in respect of any material used by the contractor in work, then in such case it shall be lawful for the SJVN and it will have right and be entitled to recover the amount paid in the circumstances as aforesaid, from the dues of the contractor.

Clause - 39 : Without prejudice to any of the rights or remedies under this contract, if the contractor dies, the Engineer-In-Charge on behalf of the SJVN shall have the option of terminating the contract with out compensation to the contractor.

Clause - 40 : The Contractor shall not be permitted to tender for works if any of his near relative who is employed as Accountant or Officer in any capacity between the grades of Superintending Engineer and Assistant Engineer (both inclusive) and responsible for award and execution of contract in the Corporation. He shall also intimate the names of the persons who are working with him in any capacity or are subsequently employed by him and who are near relatives of any officer the Corporation.

Note : By the terms relatives is meant wife, husband, parents children and grand children, brothers and sisters, uncles and cousins and their corresponding in laws.

Clause - 41 : No Engineer of gazetted rank or other gazetted Officer employed in Engineering or Administrative duties in a Engineering Department of Himachal Pradesh Government/SJVN or the Government of India is allowed to work as a contractor for a period of two years of his retirement from Government service without the permission of Himachal Pradesh Government or Government of India. The contract is liable to be cancelled if either of contractor or any of his employee is found at any time to be such a person who had not obtained the permission of Himachal Pradesh Government or Government of India as aforesaid, before submission of the tender or engagement in the contractor's service as the case may be.

Contractor

For & on behalf of SJVN Ltd.

Clause - 42 : (i) The contractor shall see that only the required quantities of material are got issued, any such material remaining unused and in perfectly good condition at the time of completion or determination of the contract shall be returned to the Engineer-In-Charge at a place as directed by him/by a notice in writing under this hand, he shall so required. Credit for such material will be given at the prevailing market rate not exceeding the amount charged from him, excluding the storage charges levied at the time of issue of materials to him. The contractor shall also not be entitled to cartage and incidental charges for returning the surplus materials from and to the stores where from they were issued.

(ii) Over this theoretical quantity of cement shall be allowed a variation upto 5% plus/minus for works upto the estimated cost of which as put to tender is not more than Rs. 2 lakhs :upto 4% plus/minus for work, the estimated cost of which put to tender is more than Rs. 2 lakhs but upto Rs. 5 lakh and upto 3% plus/minus for work, the estimated cost of which put to tender is above Rs. 5 lakhs.

The difference in quantity of cement actually issued to the contractor and the theoretical quantity including authorised variation, if not returned by the contractor, shall be recovered at twice the issue rates including storage charges, without prejudice to the provision of the relevant conditions regarding return of materials governing the contract. In the event of its being discovered that the quantity of cement used is less than the quantity ascertained as hereinbefore provided (allowing variations on the minus side as stipulated above), the cost of the quantity of cement not so used shall be recovered from the contractor on the basis of stipulated issue rates including storage charges and cartage to site.

(iii) The provisions of the foregoing sub-clause shall apply in the case of steel reinforcement or structural steel section, except that the theoretical quantity of steel shall be taken as the quantity required as per design or as authorised by the Engineer-In-Charge including authorised lap page plus 5% wastage due to cutting into pieces. Over this theoretical quantity, plus 5% and minus 4% shall be allowed as variation due to wastage being more or less.

(iv) After the completion of the works, the actual quantity of cables (other than underground cables), wire, GI/MS sheets used in various items of work shall be calculated on the basis of the measurements recorded in the measurement books for the purpose of payment and for the assessing the consumption of materials used on work over this quantity variation of 5% plus shall be allowed for wastage of materials during execution in case of cable (other than under ground cables), wires, conduit pipes, GI pipes and 10% plus in case of GI/MS sheets. The difference in quantity of materials actually issued to the contractor (s) and the quantity recorded in the measurement book including the authorised variation as stated above, if not returned by the contractor shall be recovered at twice the issue rates including storage charges and carriage to site without prejudice to the provisions of the relevant conditions regarding return of materials governing the contract.

Clause - 43 : If required by the contractor, Advance for the execution of works, whose tendered value is more than Rs.100 lakh the following cases:

(A) Advance against preliminary and enabling works. Advance to the extent of 5% (five percent) of the value of the contract can be granted for the following preliminary and enabling works.

Contractor

For & on behalf of SJVN Ltd.

- (a) Overhaul, dismantling and transportation of contractor's plant and machinery to the site of work including procurement of spare parts.
- (b) Construction of colonies, stores and workshops etc.
- (c) Construction of enabling works foundation for equipment and plant etc.
- (d) Mobilization of Labour.

The release of this advance shall be regulated and governed by the following conditions:

- i) The advance shall be interest bearing at a rate to be decided by SJVN at the time of award of work payment.
- ii) The advance to the extent of half of the total value admissible shall be released within one month of the date allotment of the contract. The rest of the advance may be released in two equal installments commensurate with the progress of above cited preliminary and enabling works on the certificate of the Engineer-In-Charge.
- iii) The advance shall be disbursed on production of irrevocable Bank Guarantee from the State Bank of India or any other scheduled bank in India on Performa at Appendix-I
- iv) The advance is recoverable and the recovery of the principle and interest thereon shall start after 20% of the value of the contracted work is paid and shall be affected, billed in such a way that the full advance and interest thereon are recovered by the time 80% (eighty percent) of value of the contract work is billed for.

(B) Machinery Advance : Advance to the extent from 1% of the value of the contract can be granted against new machinery/equipment acquired by the contractors for bonafide use on the work on the following conditions :-

- i) The item of machinery for which advance is required shall be approved by the Engineer-In-Charge.
- ii) The advance shall be interest bearing at a rate to be decided by SJVN of the time of a work of work/payment.
- iii) The advance against indigenous equipment shall be released after the equipment has reached the site of the work and is duly hypothecated in favour of SJVN on Performa at Appendix-II.
- iv) The advance against imported equipment shall be released when the equipment reaches Indian port of destination and on production of documents as a proof thereof provided the equipment is fully insured from the port to the site of work and hypothecated in favour of SJVN.
- v) The plant and machinery, so purchase shall not be insured for its full value by the contractor on the Performa at Appendix-III.
- vi) The plant and machinery, so purchased shall not be removed from site without the written permission of the Engineer-In-Charge.
- vii) The machinery and equipments, so purchased, shall be maintained in good working condition during the entire period of hypothecation.
- viii) The advance is recoverable as follows:

Recovery shall start after 20% (twenty percent) of the value of contracted work is paid and shall be effected in such a way that the full advance is recovered by the time of 80% (eighty percent) of the value of the work is billed for.

Clause - 44 : Schedule showing materials to be supplied by the SJVN under clause 10 of the conditions of contract for work contracted to be executed and the rate at which they are to be charged for:

Particular	Unit	Rate at which the material will be charged to the contractor		Place of Delivery
		Rs.	P.	
1. Cement	Tonne			Jhakri
2. Steel (Mild)	Tonne			Jhakri
3. Steel (Tor)	Tonne			Jhakri
4. Steel (structural)				
a) M. S. Angles of All sizes	Tonne			Jhakri
b) M. S. Plate 6 mm.	Tonne			Jhakri
5. C.G.I. Sheets	Tonne			Jhakri
6. Gelatine 80% Magazine or any or equivalent Kg.				Rettanpur
		other magazine in the project area.		
7. Detonator (Ordinary)	Each.			Jhakri
8. Long Delay Detonators With 3 m lead wire.	Each.			Jhakri
9. Fuse Coil	Each.			Jhakri

Note: The person or firm submitting the tenders should see that the rates in the above schedule are filled up by the Engineer-In-Charge in the issue of the form prior to the submission of the tender.

Contractor

For & on behalf of SJVN Ltd.

Appendix-i

section-iv

Performa for bank guarantee for mobilization advance

(On Non-Judicial Stamp Paper of the Requisite Value)

1. In consideration of the SJVN Limited (hereinafter called the principal) having agreed to make advance payment to (*).....

.....(hereinafter called : the said contractors (s) whose tender for

(a).....

has been accepted and to whom the acceptance of the tender, other tender documents and the letter of acceptance have been communicated for execution of formal agreement on condition of production of a Bank Guarantee for Rs.

(+).....

..... only we, the.....

..... Bank Limited (A) scheduled bank within the meaning of clause (e) of Section-2 of Reserve Bank of India, Act, 1934 hereinafter referred to as "The Bank" do hereby undertake, promise and guarantee payment to the principal on demand all the amounts advanced by the principal to the said contractor and also the amount on account of losses and damages that may be caused to or suffered by the Principal by reason of any breach of the said contractor (s) of any of the terms and conditions contained in the said tender documents, letter of acceptance or in the agreement which is to be executed in this regard, including the terms and conditions of the tender documents to a maximum of Rs. (+).....

The decision of the Principal as to whether there has been any breach as aforesaid and as to the quantum of loss suffered as result there of shall be final and binding on the Bank.

2. The Bank further agrees that the Guarantee herein contained shall remain in full force and effect, during the period that would be taken for the performance of the terms and conditions of the said tender documents, letter of acceptance and the agreement which to be executed as aforesaid and that it shall continue to be enforceable until all the dues of the principal have been duly paid and that it shall continue to be enforceable until all the dues of the Principal have been duly paid and its claims satisfied and discharged and till the principal discharge the guarantee in writing until.....which ever is earlier.

3. The Bank lastly undertakes not to revoke this guarantee until all the dues of the Principal have been duly paid except with the previous consent of the Principal in writing.

Dated the _____ day of _____ 202

Here affix the common seal

Contractor

For & on behalf of SJVN Ltd.

of the Bank for.

Bank Ltd.

- (*) Herein state the name and full address of the contractor.
- (@) Herein specify the name of the work.
- (+) The amount should be specified in figures and in words.

Contractor

For & on behalf of SJVN Ltd.

Appendix-ii

Performa for hypothecation deed for machinery advance

This indenture made this.....
day of.....
between.....hereinafter called The Contractor (which expression shall include his successors and assignees) of the one part and the SJVN Limited herein after called "the SJVN" (which expression shall include their successor and assignee's) of the other part.

Whereas

1. Pursuant to the SJVN'S Invitations of Tenders for construction of.....
..... of Rampur Hydro-electric Project in Himachal Pradesh as per stipulation contained in the SJVN item rate tender and contract for works for the guidance of the contractors the contractor submitted a tender dated.....and the SJVN accepted the contractor's said tender and awarded the work to the contractor under..... letter No.

2. The SJVN at the request of the Contractor agreed to make advance to the contractor upto a limit to Rs.....
..... against hypothecation of unencumbered machinery to the extent of 1% of the value of the contract for bonafied use on the said work on the terms and condition hereinafter appearing SJVN this indenture witnessed and it is hereby agreed and declared by and between the parties here as follows:

(i) That in consideration of the sum of Rs.....
.....agreed to be advanced by the SJVN to the contractor, the plant and machinery and equipment of the contractor fully described in the Schedule hereto, which the Contractor declares as his absolute and unencumbered and unused property, having fully and wholly paid the cost thereof and which has been brought to the site work, shall be hypothecated by way of first and specific charges as security for the repayments the SJVN on demand, of the said sum of Rs.....or so much thereof as from time to time removal due and outstanding, with cost and expenses thereof.

(ii) The above advance shall bear a simple interest of 12%. The recovery of the advance shall start after 20% of the value of work under the said Agreement is paid and shall be effected on prorata percentage basis to the value of work billed in such a way that the full advance is recovered the time 80% of the value of work is billed for.

(iii) That during the continuance of this security the SJVN shall be entitled to deduct from the contractor's running bills prorata (as para - (ii) above) from each bill for the works executed by the contractor and appropriate the same towards payment of the contractor's dues to the SJVN within the stipulated period as para (ii) above.

Contractor

For & on behalf of SJVN Ltd.

iv) That the contractor has insured that plant and machinery and equipment listed in the Schedule for their full value at this cost, against loss or damage with an Insurance Company, approved by the SJVN and that the Insurance Company has been notified that the SJVN has interest in the said policy the contractor undertakes to maintain this Insurance Policy in force till such time as the advance is fully repaid to the SJVN.

(v) That the contractor hereby undertakes not to remove the plant and machinery and equipment described in the schedule from the site of work without the written permission of the SJVN.

(vi) That the contractor hereby undertakes that the "will" not sell, transfer, convey pledge or otherwise encumber or part with the said plant and machinery and equipment described in the schedule until the aforesaid sum of advance is fully repaid to the SJVN.

(vii) That the contractor shall keep and maintain the plant and machinery and equipment in good working condition and shall not do anything to impair the value of the said plant and machinery and equipment except for normal depreciation and wear and tear and in the event of any loss or damage arising out of causes other than normal wear and tear during the period of hypothecation, the contractor shall make good such losses or damage to the satisfaction of the SJVN, failing which the SJVN shall be entitled to recover the cost of such loss or damage from the Security Deposit or from any money due to the contractor by the SJVN.

(viii) That in the event of the Contractor not repaying the aforesaid advance on demand on the event of the contractor discontinuing or not completing the works entrusted to the contractor by SJVN in terms of the said Agreement in the event of the contractor becoming insolvent the SJVN shall be at liberty to take immediate possession of the said plant and machinery and equipment and sell or otherwise dispose of the same either by public auction or by private contract and appropriate the sale proceeds thereof, after meeting the expenses of such sale towards payment of outstanding advance without prejudice to the SJVN's other rights and remedies under the said Agreement.

(ix) That the SJVN shall also be entitled without prejudice to the SJVN's other rights and remedies under the said Agreement, to rely on the amount advanced or so much thereof as shall remain due and outstanding from any dues and security deposits of the contractor in respect of the said AGREEMENT or any other contract/agreement with the SJVN.

(x) That the contractor hereby agrees to pay any stamp duty that may be assessed on this deed.

The schedule above referred to

Description	Marker's	Engine Chassis/	Purchase-	Tot. cost
90%				
of machinery	Name	No. No. Plant/No.	ed from	as per the of
No.		bill	cost.	

in witness where of the parties have hereunder set and subscribed their respect hands hereinto the day and year first above written.

Signed, Sealed and delivered

Contractor

For & on behalf of SJVN Ltd.

of.....

for and on behalf

.....
designation)

(name and

- 1.
- 2.
- 1.

In presence of :-
Signed for and on behalf of
the SJVN.

(name and designation)

.....

Performa for insurance of machinery equipment

From

Name of the Contractor

To

Insurance Company (with whom the plan, machinery and equipment is insured).

Dear Sir,

I am to inform you that the SJVN is interested in the Insurance Policy No. secured in your company and to request that you will kindly interest a clause to the following effect in the policy.

Clause to be inserted in the Insurance Policy:

1. It is hereby declared and agreed that M/s.....
.....
..... (the owner of the plant and machinery and equipment, hereinafter referred to as the insured in schedule to this policy) has hypothecated the plant and machinery and equipment to the SJVN as security and it is further declared and agreed that the SJVN is interested in any money which but for the endorsement be payable to the said Insured in respect of the loss or damage to the said plant and machinery and equipment (which, loss or damage is not made good by repaid reinstatement or replacement) and such money shall be paid to the SJVN as long as the SJVN is the mortgage of the plant and machinery and equipment and its receipt shall be full and final discharge to the company irrespective of such loss or damage.
2. Save as by this endorsement expressly agree nothing herein shall modify or effect the rights of liabilities of the insured or the company, respectively, under or in connection with this policy or any term provision or condition thereof.

Yours faithfully

Place:

Date:

appendix-iv

Performa bank guarantee in lieu of earnest money

Contractor

For & on behalf of SJVN Ltd.

(on non-judicial stamp paper)

Ref..... Date.....

To

Bank Guarantee No.....

SJVN Limited
Himfed Building
New Shimla (H. P.)

Dear Sir,

In accordance with your notice Inviting Tenders for.....under your specification No. Dated M/s. (Hereinafter called the tender) with the following directors on their Board of Directors/partners on the firm.....

- | | |
|--------|---------|
| 1..... | 2..... |
| 3..... | 4..... |
| 5..... | 6..... |
| 7..... | 8..... |
| 9..... | 10..... |

wish to participate in the said tender/following tenders :

- 1.....
- 2.....
- 3.....

Whereas it is a condition in the tender documents that the tenderer has to deposit Earnest money with respect to the tender with SJVN Limited (thereinafter effect to as "Corporation") amounting to Rs.....or alternatively the tenderer is required submit Bank Guarantee from a nationalized bank, irrevocable and operative till 30 days after validity of the offer, for the like amount which amount is likely to forfeited on the happening contingencies mentioned in the tender documents.

And whereas the tenderer desire, to secure exemption from deposit of Earnest Money and has offered to furnish a bank guarantee for a sum or Rs.....to the Corporation for the purpose of securing exemption from the deposit of Earnest Money.

Now THEREFORE, we the.....Bank, a body corporate

constituted under the Bank the Contractor Companies Acquisition and Transfer of Undertakings Act, 1969 and having a branch office at.....(hereinafter referred to as the 'Bank') do hereby undertake and agree to pay on demand in writing by the Corporation, the amount of Rs.....Rupees.....) to the SJVN Limited without any demur, reservation or recourse.

Contractor

For & on behalf of SJVN Ltd.

We, the aforesaid Bank, further agree that the Corporation shall be the sole judge of and as to whether the tenderer has committed any breach or breaches of any of the terms and conditions of the tender and the extent of loss, damage, costs charges and expenses caused to or suffered by or that may be caused to or suffered by the Corporation on account thereof. The extent of the Earnest Money required to be deposited by the Tenderer in respect of the said Tender Document and the decision of the Corporation that the tenderer has committed such breach or breaches and as to the amount or amount of loss, damage, costs charge and expenses caused to or suffered by or that may be caused to or suffered by the Corporation shall be final and binding on us.

We, the said Bank further agree that the Guarantee herein contained shall remain in full force and effect until it is released by the Corporation and change in the constitution, liquidation or dissolution of the Tenderer, shall not discharge our liability guaranteed herein.

It is further declared that it shall not be necessary for the Corporation to proceed against the Contractor before proceeding against the Bank and the Guarantee herein contained shall be enforceable against the Bank notwithstanding any security which the Corporation may have obtained or shall obtain from the Contractor at the time when proceedings are taken against the Bank for whatever amount may be outstanding or unrealized under the guarantee.

The right of the Corporation to recover the said amount of Rs..... (Rupees) from us in the manner aforesaid will not be affected by reason of the fact that any dispute or disputes have been raised by the said M/s.....(Tenderer) and/or that any dispute or disputes are pending before any authority, officer, tribunal or arbitrator (s) etc.

Notwithstanding anything stated above, our liability under this guarantee shall be restricted to Rs.....(Rupee.....) and out guarantee shall remain in force uptoand unless a demand or claim under the guarantee is made on us in writing within three months after the aforesaid date i.e. on or before the.....all your rights under the guarantee shall be forfeited and we shall be relieved and discharged from all liabilities there under.

Date..... Signature.....
Place..... Name.....

Designation.....

Bank's common

Seal.....

Authorization

No.....

In presence of :

Witness :

1

2

Contractor

For & on behalf of SJVN Ltd.

appendix-v
Performa bank guarantee in lieu of security deposit
in individual contract
(on non-judicial stamp paper)
To

SJVN Limited
Contractor

For & on behalf of SJVN Ltd.

Himfed Building, New Shimla (H. P.)

In consideration of the Satluj Jal Vidyut Nigam Ltd. (.....) (hereinafter called the "Corporation" which expression shall unless repugnant to the subject or context include its administrators, successors and assigns) having agreed under the terms and conditions of Contract No.....dated.....made between *.....and the Corporation in connection with.....(hereinafter called the said Contract) to accept a Deed of Guarantee as herein provided for Rs.....from a nationalized bank in lieu of the security deposit to be made by the contractor or in lieu of the deduction to be made from the contractor's bills for the due fulfilment by the said contractor of the terms and condition contained in the said contract, we, the..... Bank, a body corporate constituted under the Banking companies (Acquisition and Transfer of Undertakings Act, 1969 and having a branch office at.....(hereinafter referred to as "the said Bank") and having our registered office at.....do hereby undertake and agree to indemnify the Corporation from time to time to the extent of Rs..... (Rupees.....) only against any loss or damage, costs, charge and expenses caused to or suffered by or that may be caused to or suffered by the Corporation by the reason of any breach or breaches by the said Contractor of any of the terms and conditions contained in the said contract and to unconditionally pay the amount claimed by the Corporation on demand and without demur to the extent aforesaid.

We.....Bank, further agree that the Corporation shall be the sole judge of and as to whether the said contractor has committed any breach or breaches of any of the terms and conditions of the said contract and the extent of loss, damage, cost charge and expenses caused to or suffered by the Corporation on account thereof and the decision of the corporation that the said contractor committed such breach or breaches and so to the amount or amounts of loss, damage, costs, charge and expenses caused to or suffered by or that may be caused to or suffered by the Corporation from time to time shall be final and binding on us.

We, the said Bank, further agree that the guarantee herein contained shall remain in full force and effect during the period that would be taken for the performance of the said contract and till all the dues of the Corporation under the said contract or by virtue of any of the terms and conditions governing the said contract have been fully paid and its claims satisfied for discharged and till.....certified and properly carried out by the said contractor and accordingly discharges the Guarantee after..... Years from the date of

expiry of the Defect Liability Period as provided in the said contract or from the date of cancellation of said contract, as the case may be unless a notice of the claim under this Guarantee has been served on the Bank before the expiry of the said period of.....years in which case the same shall be force able against the Bank

Contractor

For & on behalf of SJVN Ltd.

notwithstanding the fact, that the same is enforced after the expiry of the said period of.....years.

The Corporation shall have the fullest liberty without affecting in any way the liability of the bank under this Guarantee or indemnity, from time to time to vary of any of the terms and conditions of the said contract or to extend time of performance by the said contractor or to postpone for any time and from time to time any of the performance by the said contractor or to protractor and either to enforce or forbear from enforcing any of the terms and conditions governing the said contract or securities available to Corporation and the said Bank shall not be released form its liability under these presents by any exercise by the Corporation of the liberty with reference to the matters aforesaid or by reasons of time being given to the said contractor or any other forbearance, act or omission on the part of the Corporation or any indulgence by the Corporation to the said Contractor or any other matter or things whatsoever which under the law relating to sureties would but for this provision have effect of so releasing the Bank from its such liability.

It shall not be necessary for the Corporation to proceed against the Contractor before proceeding against the Bank land the guarantee herein contained shall be enforceable against the Bank, notwithstanding any security which the Corporation may have obtained or shall obtain from the contractor at the time when proceedings are taken against the Bank for whatever amount be outstanding or unrealized. We, the said Bank lastly undertake not to revoke this Guarantee during its currency except with the previous consent of the Corporation in writing and agree that any change in the constitution of the said contractor or the said Bank shall not discharge our liability hereunder. If any further extension of this Guarantee is required, the same shall be extended to such required period on receiving instruction from M/s.....on whose behalf this Guarantee is issued.

In the presence of :

Witness :	For and on behalf of the Bank	
	Bank's	Common
Seal.....	Name	&
Designation.....		
.....	Authorisation	
No.....	Date	and
Place.....		
.....		

The above Guarantee is accepted by the SJVN Limited

For and on behalf of the SJVN Limited

Contractor

For & on behalf of SJVN Ltd.

(.....
Hydro-electric Power Project)

of.....

Signature.....

Dated.....
(Name and Designation)

notes :

* For Proprietary Concerns

Shri.....son

of.....

resident

of.....carring on

business under the name style

of.....at

which expression shall unless the context requires otherwise include his heirs, executors an legal representatives.

* For Partnership Concerns

M/s.....a

partnership firm

with its office.....(hereinafter called "the said Contractor"

which expression shall unless the context requires otherwise include their heirs, executors, administrators); the names of the partners being (i)

Shri.....son

of.....etc.....

* For Companies

M/s..... a company under the Companies Act.

1956 and having its registered office in the State of.....(hereinafter

called "the said Contractor" which expression shall unless the context requires otherwise include its administrators, successors and assigns).

Contractor

For & on behalf of SJVN Ltd.

section - V
special conditions of contract

1. While tendering for the work the contractor is supposed to have seen the site of work and no special claims on account of difficulties arising due to the situation of the site will be entertained.
2. The work shall be carried out as per the drawings supplied by the department and as

Contractor

For & on behalf of SJVN Ltd.

per the instructions of the Engineer-In-Charge. The General specification shall be latest central public works department standard specification with upto date correction slips except where otherwise specified in description of items given in the schedule of quantities.

3. The work shall be carried out in manner complying in all respects with the requirements of relevant by laws of the local bodies in whose jurisdiction the work is situated.

4. Hard stone and other materials shall be obtained from approved quarries, royalties, taxes, municipal octroi, other incidental charges in connection with their supply to the site of work shall be borne by the contractor himself.

5. When any surplus earth is to be disposed off the site where the earth would be disposed off should be got approved form Engineer-In-Charge in writing before undertaking the work. The disposal of rubbish and debris due to construction work will be the contractor's responsibility and nothing shall be paid extra for this disposal.

6. Owing to difficulty in obtaining certain material in open market, the SJVN have under taken to supply materials specified on page III-30 of the tender from at the rates stated therein there may be delay in obtaining the materials by the department and the contractor is therefore to keep himself in touch with day to day position regarding supply of materials from Engineer-In-Charge and so adjust the progress of work that his labour may not remain idle.

It should be clearly understood that no claim whatsoever shall be entertained by SJVN on account of delay in supplying materials.

7. The contractor must ensure before taking delivery of materials from stores that these are good condition and on claim on account of the material being defective will be entertained later on. If these are delivered at any other site than specified in the agreement, the difference due to carriage will be adjusted accordingly.

8. The cement shall be stacked by the contractor in a separate godown built by him a this cost having water proof roof and wall and floor consisting of layer of dry bricks/stone laid on well consolidated earth at least 300 mm above ground level. These stacks shall be in rows of 2 bags deep and 10 bags high and with minimum 600 mm clear space around, the bags shall be placed horizontally continuous in each line. Nothing extra will be paid for this.

9. The contractor shall be required to make double lock arrangement for other valuable materials at the site of work. One key will remain in the custody of Engineer-In-Charge of the work and the other with the representative of the contractor an locking arrangement should be such that godown cannot be opened unless the contractor and Junior Engineer are present.

10. No hand mixing of the concrete will be allowed. The contractor will have to arrange for concrete mixers himself.

Contractor

For & on behalf of SJVN Ltd.

11. The contractor shall also be responsible for watch and ward of other materials issued to him. If contractor fails to provide sufficient fencing, lighting and watch to the satisfaction of the Engineer-In-Charge, the later after notice to the contractor will provide sufficient fencing, lighting and watching staff. The cost of doing so shall be deducted from the contractor but such action on the part of the Engineer-In-Charge in providing sufficient, fencing and lighting shall not relieve the contractor from responsibilities for damages caused by failure on his part.

12. No payment shall be made to the contractor for any damages caused to work or material rains/snow or floods or due to any other cause, whatsoever, during the execution of the work and no such claim on this account shall be entertained. He will have to make good all such damages at his own cost.

13. The contractor shall not deposit material on any site which will seriously cause inconvenience to the public. The Engineer-In-Charge may require the contractor to remove any material which is considered by him to be a danger or inconvenience to the public caused at his cost.

14. Recovery for damaged material due to defective storage of material issued by the department will be recovered from the contractor at double the issue rate. No claim on this account shall be entertained.

15. The contractor should obtain permission from the Engineer-In-Charge for extracting stores from road sides or approved quarries and amount of royalty to be deducted on this account shall be fixed by the Engineer-In-Charge in consultation with the concerned department.

16. The contractor shall be responsible to make good the damage caused to the lands and buildings of private persons which are continuous or otherwise to the premises on which the work or any part of it is being executed and on his failure to do so. The same will be made good by the Engineer-In-Charge at the cost of contractor.

17. Any damages during the execution of work will be the responsibility of the contractor. He will have to restore such damages at his own cost and nothing will be paid by SJVN on this account.

18. Sample of all materials to be used on the work be submitted for approval to the Engineer-In-Charge before hand. The same Principle will hold good for all the items of work.

19. The design of shuttering must be submitted by the contractor to the Engineer-In-Charge before hand for obtaining his written approval before erection of the same. The contractor shall be entirely responsible for the failure of the shuttering due to noncompliance of the instructions and due to imperfection in erection and execution.

20. All reinforcement has to be placed in the position as shown in the drawings. In case any reinforcement is found to have been misplaced/displaced, the contractor alone will be

Contractor

For & on behalf of SJVN Ltd.

responsible for the same. The Engineer-In-Charge will be at liberty to reject all such work or sub work as sub-standard or to deduct for reduction due to wrong placing.

21. All jungle clearance such as shrubs etc. will be done by the contractor at his own cost but the trees big or small shall not be felled without prior permission. Cost of damage to the forest or to some other Government or private properties will be made good by the contractor at his own cost or recovery shall be made from his bill.

22. The contractor shall produce a labour clearance certificates from the labour inspector concerned, before final payments are released to him.

23. The contractor shall himself remain or keep his duly authorised representatives at site during all working hours of execution to receive instruction from Engineer-In-Charge or his subordinate officer to carry out the work accordingly.

24. All material brought to the site or work during the time of execution should be stacked properly as per instructions issued by the Engineer-In-Charge.

25. The Engineer-In-Charge will be at liberty to debit the contractor's account with any dues outstanding against him in respect of some other work entrusted to him by SJVN.

26. In case the contractor obtains route permit for plying his own or hired truck for the carriage of materials to the site of work, he shall tender full account of the carriage work done by him duly supported with the log book of the vehicles weekly, failing which he will be liable to pay fine at the rate of Rs. 5 per day for extra days that the truck has plied.

27. The rates of different items are for all heights, depths and widths unless otherwise specified against the items.

28. For testing the strength of concrete cubes shall be prepared by the contractor under supervision of an officer of the department not below the rank of sub-division officer. Sample of concrete and its testing shall be done as per relevant specification and also as per relevant I. S. Codes of practice and tested in recognized laboratory approved by the Engineer-In-Charge. The cost of making cubes and carriage to laboratory shall be borne by the Contractor. The Contractor shall, however, abide by the decision of the Engineer-In-Charge. In case the result of test shows the work not being upto the specified standard, contractor will carry out any order necessitated thereby at his own cost.

29. The contractor shall get frames and other items of wood work approved by the Engineer-In-Charge before fixing the same. All wood work shall be done out of properly seasoned wood. The wood work should not be painted or treated in any other way until it is approved by the Engineer-In-Charge.

30. The samples of iron fittings and other fitting i. e. fan clamp, hooks, rings wooden handrail, iron railing, paints of different shades, marble, chips etc. shall be approved by the Engineer-In-Charge before fixing and laying

Contractor

For & on behalf of SJVN Ltd.

31. In case where brick work is exposed and is required to be finished with pointing or otherwise selected brick should be used and nothing extra will be paid to the contractor on this account.
32. In case of brick masonry items, the classification of bricks brought by the contractor shall strictly confirm to the relevant specification referred to above irrespective of the classification shown on the permit if any issued to the contractor by the supply department. The contractor shall have no claim whatsoever on this account.
33. The contractor shall clear the site properly after the completion of the work.
34. The contractor shall maintain in good condition all works during execution till completion of entire work allotted to the contractor.
35. The contractor must take all precautions to avoid all accidents by exhibiting day and night necessary sign boards, speed limit, boards, red flags and red lights and providing barriers. He shall be responsible for all damages and accidents caused due to negligence on his part. No hindrance shall be caused to traffic during the execution of work.
36. Any departmental officer is authorised to have access to the godown for purpose of inspection of materials at any time. Any material which inspecting officer may point out as being below the required standard will be removed entirely at once from the site of work by the contractor and not used on SJVN work. No claim on this account shall be entertained.
37. Wherever pipes are to be fixed to wall or R. C. C. surface the contractor may be required to use raw plugs for which nothing extra shall be payable. The contractor shall ensure that vertical pipes are truly vertical and horizontal pipes are truly horizontal.
38. In the event of dispute of any kind arising out of this contract the law court at the district headquarter of the Engineer-In-Charge or high Court of Himachal Pradesh Shimla, shall have the jurisdiction.
39. The contractor shall allow deduction of income tax at source as required under section 194 (C) of the Income Tax Act, 1961.
40. The material shall be issued to the contractor at the place of delivery as mentioned in the schedule showing materials to be supplied by SJVN under clause
- 43 (B). If these are delivered at any other site, the difference due to cartage will be adjusted accordingly. The contractors have to bear at their cost the material to the site of the work as soon as these are issued. The contractor shall bear all incidental charges for cartage, storage and safe custody of materials.

Contractor

For & on behalf of SJVN Ltd.

41. The contractor shall make his own arrangements for obtaining electric and water connections and make necessary payments direct to the Deptt. concerned. SJVN will only help in recommending the same to the concerned department.

42. contract quality assurance

The bidder shall include in his proposal the Quality Assurance Programme Covering the overall quality management and procedures which he proposes to follow in the performance of the works during various phases as detailed in relevant of the Technical specifications.

At the time of award of contract, the detailed quality Assurance and Testing Plan to be followed for the execution of the contract will be discussed and mutually agreed to and

such agreed programme shall form a part of the contract.

(A) quality assurance programme

To ensure that equipment and services under the scope of this contract whether manufactured or performed within the Contractor's Works or at his Sub-Contractor's premises or at the owner's site or at any other place of work are in accordance with the specifications, the Contractor shall adopt suitable quality assurance programme, to control such activities at all points necessary. Such programme shall be outlined by the Contractor and shall be finally accepted by the Engineer after discussions before the award of the contract. A quality assurance programme of the contract shall generally cover the following:-

- a) His organization structure for the management and implementation of the proposed quality assurance programme.
- b) Documentation of control system.
- c) Qualification data for bidder's key personnel.
- d) The procedure for purchase of materials, parts components and selection of Sub-contractor's services including vendor analysis, source inspection, incoming raw material inspection, verification of materials purchases etc.
- e) System for shop manufacturing and site erection controls including process controls and fabrication and assembly controls.
- f) Control of non-conforming items and system for corrective actions.
- g) Inspection and test procedure both for manufacturer and field activities.
- h) Control of calibration and testing of measuring and testing equipments.
- i) System for indication and appraisal of inspection status.
- j) System for quality audits.
- k) System for maintenance of records.
- l) System for authorizing release of manufactured product to the owner.
- m) System for handling storage and delivery.
- n) A quality plan detailing out the specific quality control procedure adopted for controlling the quality characteristics relevant to each item of equipment furnished.

The Engineer or his duly authorised representative reserves the right to carry out quality audit and surveillance of the system and procedure of the Contractor/his vendor's quality management and control activities,

(b)

(c) quality assurance documents

Contractor

For & on behalf of SJVN Ltd.

The contractor shall be required to submit the following Quality Assurance Documents within three weeks after dispatch of the equipment:

- (i) All Non-destructive Examination procedure, stress relief and weld repair procedure actually used during fabrication.
- (ii) Welder and Welding operation qualification certificates.
- (iii) Welder identification list, listing Welder's and Welding operator's qualification procedure and welding identification symbols.
- (iv) Material mill test reports on components as specified by the specification.
- (v) The inspection plan with verification, inspection plan check points, verification sketches, if used and methods used to verify that the inspection and testing points in the inspection plan were performed satisfactorily.
- (vi) Sketches and drawings used for indicating the method of tractably of the radiographs to the location on the equipment.
- (vii) All Non-destructive Examination result report including radiography interpretation of reports.
- (viii) Stress relief time temperature charts.
- (ix) Factory test results for testing required as per application codes and standard referred in the specifications.
- (x) The Engineer or his duly authorised representative the right to carry out Quality audit and Quality Surveillances of the systems and procedures of the contractors/his vendor's Quality Management and Control activities.

43. The contractor shall have to manage a portable explosive magazine at the site of work at his own cost.

44. Explosive material issued to the contractor will have to be used as per explosive Act and in case no more than one day's requirement will be lifted from the explosive magazine.

45. The contractors may have to do controlled blasting in some reaches of the roads as per the directions of Engineer-In-Charge in order to avoid damage to the existing nearby structures.

46. Serviceable stones from the excavation of foundation and road cutting available will be stacked properly along site development road site, keeping width of the road clear by the contractor at his own cost.

Contractor

For & on behalf of SJVN Ltd.

47. All trees falling in the alignment of road in the private and acquired for the construction of road shall be felled/cut by the contractor and quantity of wood timber, so received shall handed over to the department. No extra payments shall be made on this account. In case of the contractor fails to handover the same to the department, the cost of trees shall be recoverable from the contractors at the rate of acquisition of such trees.

48. One third (1/3rd) useful stones as obtainable from the quantity of blasting work shall be stacked properly at site being SJVN property by the contractor as per the instructions of the Engineer-In-Charge, failing which recovery market rates only per cum will be made from the contractor.

49. No extraction of stone will be allowed surrounding the site of work/project area the contractor should arrange stone himself from the approved quarry.

50. In case dewatering is required to be done by the contractor, it shall be done entirely by him at his own cost. No claims in this regard shall be entertained.

51. Contractor shall have to produce M-forms for the material utilised such as stone aggregate, sand etc.

Annexure–A
Section – vi

safety code

(referred to under clause 19 – C of the tender)

(i) Suitable scaffolds should be provided for workman for all works that cannot safely be done from the ground or from solid construction except such short period work as can be done safely from ladders, When a ladder is used an extra Mazdoor shall be engaged for holding the ladder and if the ladder is used for carrying materials as well suitable foot holds and hand holds shall be provided on the ladder and ladder shall be given an inclination not steeper than $\frac{1}{4}$ to 1 ($\frac{1}{4}$ horizontal and 1 vertical).

(ii) Scaffolding or staging more than 3.6 m above the ground or floor, swung or suspended from an overhead support or erected with stationary support shall have a guard rail properly attached bolted, braced and otherwise secured at least 90 cm high above the floor or platform of such scaffolding or staging and extending along the entire length of the outside and ends therefore with only such opening as may be necessary for the delivery of the materials. Such scaffolding or staging shall be so fastened as to prevent it from swaying from the building or structure.

Contractor

For & on behalf of SJVN Ltd.

(iii) Working platform, gangways should be so constructed that they should not sag unduly or un equally and if the height of the platform or the gangway or the stairway is more than 3.6 m above ground level or floor, they should be closely boarded, should have adequate with and should be suitable fastened as described in (ii) above.

(iv) Every opening in the floor of a building or in a working platform be provided with suitable means to prevent the fall of persons or materials by providing suitable fencing or railing whose minimum height shall be three feet.

(v) Safe means of access shall be provided to all working platform and other working place every ladder shall be securely fixed. No portable single ladder shall be over 9 m in length while the width between side rails in hung ladder shall in no case be less than 20 cm for ladder upto and including 3 m in length. For longer ladder this width should be increased at least 20 mm for each additional metre of length. Uniform step spacing shall not exceed 30 cm. Adequate precautions shall be taken to prevent danger from electrical equipment . No materials on any of the sites of work shall be so stacked or placed as to cause danger or inconvenience to any person or the public. The contractor shall provide all necessary fencing and lights to protect the public from accident and shall be found to bear the expenses or defense of every suit, action or other proceedings at law that may be brought by any person for injury sustained owing to neglect of the above precautions and to pay any damages and cost which may be awarded in any such suit, action or proceedings to any such persons or which may with the consent of the contractor be paid to compromise any claim by any such person.

(vi) All Trenches, 1.2 m or more in depth, shall at all times be supplied with at least one ladder for each 30 m in length or fraction thereof. Ladder shall be extended from bottom of the trench to at least 90 cm above the surface of the ground. The site of the trenches which are 1.5 m or more in depth shall be stepped back to give suitable slope or securely held by timber bracing, so as to avoid the danger of sides to collapse.

The excavated material shall not be placed within 1.5 m of the edges of the trench or half of the depth of the trench whichever is more. Cutting shall be done from top to bottom. Under no circumstances under mining or under cutting shall be done.

(vii) Before any demolition work is commenced and also during the process of the work :

a) All roads and open areas adjacent to the work site shall either be closed or suitable protected.

b) No electrical cable or apparatus which is liable to be source of danger over acable or apparatus used by the operator shall remain electrically charged.

(c) All practical step shall be taken to prevent danger to persons employed from risk of fire or explosion of flooding No floor, roof or other part of the building shall be so over loaded with debris or materials to render it unsafe.

(viii) All necessary personal safety equipment as considered adequate by the Engineer-In-

Contractor

For & on behalf of SJVN Ltd.

Charge should be kept available for the use of the person employed on the site and maintained in a condition suitable for immediate use and the contractor should take adequate steps to ensure proper use of equipment by those concerned.

- a) Workers employed on mixing asphaltic materials, cement and lime mortars shall be provided with protective footwear and protective goggles.
- b) Those engaged in white washing and mixing or stacking of cement bags or any material which is injurious to the eyes shall be provided with protective goggles.
- c) Those engaged in welding works shall be provided with welder's protective eye sightless.
- d) Stone breakers shall be provided with protective goggles and protective clothing and seated as sufficiently safe intervals.
- e) When workers are employed in sewers and manholes, which are in use the Contractor shall ensure that the manhole covers are opened and are ventilated at least for an hour before the works are allowed to get into the manholes and manholes so opened shall be cordoned off suitable raining and provided with warning signals or boards to prevent accident to the public.
- f) The contractor shall not employ men below the age of 18 years and women on the work of painting with products containing lead in any form. Whenever men above the age of 18 are employed on the work of lead painting the following precautions should be taken.
 - i) No paint containing lead or lead products shall be used except in the form of paste or ready made paints.
 - ii) Suitable face masks should be supplied for use by the workers when paint is applied in the form of spray on a surface having lead paint dry rubbed and scrapped.
 - iii) Overalls shall be supplied by the contractors to the workman and adequate facilities shall be provided to enable the working painters to wash during the cessation of work.
- ix) When the work is done near any place where there is risk of drowning, all necessary equipments should be provided and kept ready for use and all necessary steps taken for prompt rescue of any person in danger and adequate provision should be made for prompt first aid treatment of all injuries likely to be sustained during the course of the work.
- x) Use of hoisting machines and tackle including their attachments, anchorage and supports shall conform to the following standards or conditions.

Contractor

For & on behalf of SJVN Ltd.

1. a) These shall be of good mechanical construction, sound material and adequate strength and free from patent defect and shall be kept in good repair and in good working order. (b) Every rope used in hoisting or lowering materials or as a means of suspension shall be of durable quality adequate strength and free from patent defects.
2. Every crane or hoisting appliance operator shall be properly qualified and no person under the age of 21 years should be in charge of any hoisting machine including any scaffold or which given single to operator.
3. In case of every hoisting machine and of every crane ring hook, shackle survival and pulley block used in hoisting or as means suspension the safe working load shall be as curtailed by adequate means. Every hoisting machine and all gear referred to above shall be plainly; marked with the safe working load in case of hoisting machine having variable safe working load each safe working load of the conditions under which it is applicable shall be clearly indicated. No part of any machine or any gear referred to above in this paragraph shall be loaded beyond the safe working load except for the purpose of testing.
4. In case of departmental machines, the safe working load shall be notified by the Electrical Engineer-In-Charge. As regards contractors machine the contractors shall notify the safe working load of the machine to the Engineer-In-Charge whenever he brings any machinery to site of work and get it verified by the Electrical Engineer concerned.

(xi) Motors Gearing, Transmission, Electric wiring and other dangerous part of hoisting appliance should be provided with efficient safeguards, hoisting appliances should be provided with such mean as will reduce to minimum the risk of any accidental descent of the load, adequate precaution should be taken to reduce to the minimum the risk of any part of suspended load becoming accidentally displaced. When worker employed is on electrical installations which are already energized insulating mates, wearing apparel, such as gloves sleeves and both as may be necessary should be provided. the workers should not wear any rings, watches and carry keys or other material which are good conductors of electricity.

(xii) All scaffold ladders and other safety devices mentioned or described herein shall be maintained in safe condition and scaffold, ladder or equipment shall be altered or removed while it is in use. Adequate washing facilities should be provided at or near places or work.

(xiii) These safety provision should be brought to the notice of all concerned by display on a notice board be at prominent place at work spot. The person responsible for compliance of the safety code shall be named therein by the contractor.

(xiv) To ensure effective enforcement of the rules and regulations relating to safety precautions, the arrangements by the contractor shall be open to inspection by the labour officer/ Engineer-In-Charge of the department or their representative.

(xv) Notwithstanding the above clauses from (i) to (xiv) there is nothing in these to exempt the contractor from the operation of any other Act/Rule in force in the Republic of India.

Annexure–B

Model Rules for the Protection of Health and Sanitary arrangements for workers employed by SJVN Limited or its Contractor

Application : These rules shall apply to all building and construction work in charge of SJVN.

Definitions :

1. 'Work place' means a place at which at an average fifty or more workers are employed connection with construction work.
2. 'Large work Place' means a place at which, at an average 500 or more workers are employed in connection work.
3. First Aid : (a) At every work place, there shall be maintained in a readily accessible place first aid appliances including an adequate supply of sterilized dressing and sterilized cotton wool. The appliances shall be kept in good order and in large work place, they shall be placed under charge of a responsible persons who shall be readily available during working hours.

b) At large work places, where hospital facilities are not available within easy distance of the works, First Aid posts shall be established and be run by a trained compounder.

Contractor

For & on behalf of SJVN Ltd.

- c) Where large work places are remoter from regular hospitals, an indoor ward shall be provided with one bed for every 250 employees.
- d) Where large work places are situated in cities, towns or in their suburbs and no beds are considered necessary owing to the proximity of city or town hospitals, suitable transport shall be provided to facilities removal or urgent cases to the hospitals. At other work places conveyance facilities such as a car, shall be kept readily available to take injured persons suddenly taken seriously ill to the nearest hospital.
4. Drinking water : (a) In every work place, there shall be provided and maintained at suitable places, easily accessible to labour, a sufficient supply of cold water fit for drinking.
- b) Where drinking water is obtained from an intermittent public water supply, each work place shall be provided with storage where such drinking water shall be stored.
- c) Every water supply source or storage shall be at a distance of not less than 15 mtr. from any latrine, drain or other source of pollution. Where water had to be drawn from an existing well which is within such proximity of latrine, drain or any other source of pollution, the well shall be properly chlorinated before water is drawn from it for drinking. All such wells shall be entirely closed in and be provided with a trap door which shall be dust and water proof.
- d) A reliable pump shall be fitted to each covered well, the trap door shall be kept locked and opened only for cleaning or inspecting which shall be done at least once a month.
5. Washing and bathing places : (a) Adequate washing and bathing places shall be provided, separately for men and women.
- b) Such place shall be kept in clean drained condition.
6. Scale of accommodation in latrines and urinals. These shall be provided within the precincts of every work place, latrines and urinal in an accessible place and the accommodation separately for each of them shall not be less than the following scale :
- (a) Where the number of persons does not exceed 50 2 seats
- (b) Where the number of persons exceeds 50 but does not exceed 100 3 seats
- (c) For every additional 100 3 seats per 100
- In particular cases, the Engineer-In-Charge shall have the powers to vary the scale, where necessary.

Contractor

For & on behalf of SJVN Ltd.

7. Latrines and urinals for women : If women are employed separate latrines and urinals screened from those for men and marked in the vernacular in conspicuous letters "For Women only" shall be provided on the scale laid in rule 6. Those for men shall be similarly marked "For Men Only". A poster showing the figures of a man and woman shall also be exhibited at the entrance of latrines for each sex. There shall be adequate supply of water close to the urinals and latrines.
8. Latrines and urinals : Except in work places provided with water flushed, latrines, connected with a water borne sewage system, all latrines shall be provided with receptacles on dry earth system which shall be cleaned at least four times daily and at least twice during working hours and kept in a strictly sanitary conditions. The receptacles shall be tarred inside and outside at least once a year.
9. Construction of latrines : The inside walls shall be constructed of masonry or some suitable heat resisting nonabsorbent materials and shall be cement washed inside and outside at least once a year. The dates of cement washing shall be noted in a register maintained for this purpose and kept available for inspection. Latrines will not be of a standard lower than bore hole system and should have thatched roof.
10. Disposal of excreta : Unless otherwise arranged for by the local sanitary authority, arrangements for proper disposal of excreta by incineration at the work place shall be made by means of a suitable incinerator approved by the Assistant Director of Public Health or the Municipal Medical Officer of Health, as the case may be in whose jurisdiction the work place is situated. Alternatively, excreta may be disposed off by putting a layer of night soil at the bottom of pucca tank prepared for the purpose and covering it with 15 cm layer of waste or refuse and then covering it up with a layer of earth for a fortnight (when it will turn into manure).
11. Provision of shelters during rest : At every work place there shall be provided, free of cost, two suitable sheds one for meals and the other for rest separately for men and women for the used of labour. The height of the shelter shall not be less than 3.3 m from the lowest part of the roof. The sheds should be roofed with at least thatch and mud flooring will be provided with a dwarf wall around not less than 75 cm. Sheds should be kept clean and the space should be on the basis of atleast 0.46 square meter per head.
12. Crèches : (a) At every work place, at which, 50 or more women workers are ordinarily-employed, there shall be provided two huts for the use of children under the age of 6 years, belonging to such women. One huts shall be used for infants, games and play and the other as their bed room. The huts shall not be constructed on a lower standard than following :
 - (i) Thatched roofs
 - (ii) Mud floors and walls

Contractor

For & on behalf of SJVN Ltd.

(iii) Planks spread over the mud floor and covered with matting.

The huts shall be provided with suitable and sufficient openings for light and ventilation. There will be adequate provision of sweepers to keep the place clean. There shall be two Dais in attendance. Sanitary utensils shall be provided to the satisfaction of the Health Officer of the area concerned. The use of the hut shall be restricted to children, their attendants and mothers of the children.

b) Where the number of women workers are more than 25 but less than 50, the contractor shall provide atleast one hut and one dia to look after the children of woman workers.

c) The size of creche shall vary according to the number of women workers.

d) The creche or creches shall be properly maintained and necessary equipment like toys etc. shall be provided.

13. Canteen : A cooked food canteen on a moderate scale shall be provided for the benefit of workers wherever it is considered expedient.

14. The above rules shall be incorporated in the contractors and in notices inviting tenders and shall form an integral part of the contracts.

Annexure–C

Nathpa Jhakri Hydro-electric Project Contractors Labour

Regulations Extended to SJVN LIMITED

1. Short title : These regulations may be called the Rampur Jhakri Hydro-electric Project Contractors Labour Regulations.
2. Definitions : In these regulations, unless otherwise expressed or indicated, the following words and expressions shall have the meaning hereby assigned to them respectively that is to say.
 - (i) 'Labour' means workers employed by SJVN Ltd. Contractor directly, or indirectly through a sub-contractor or other persons or by an agent on his behalf on a payment as per rules of H. P. Govt. will not include supervisory staff like Overseers etc.
 - (ii) 'Fair wages' means wages whether for time or piece work notified at the time of inviting tenders for the work and where such wages have not been so notified, the wages prescribed by the SJVN for wages the district in which the work is done. It will be notified/prescribed by the SJVN in consultation with the officer of the industrial Relations Machinery located in the respective areas and will not be less than the minimum rates of wages fixed by the Government for the class of employee engaged on the same type work in the same area.
 - (iii) 'Contractor' shall including every person whether a sub contractor or headman or agent, employing labour on the work taken on contract.
 - (iv) 'Wages' shall have the same meaning as defined in the payment of wages Act and includes time and piece rate wages.
2. (a) Normally working hours of an employee should not exceed 9 hours a day The working day shall be so arranged that inclusive of interval for rest, if any, it shall not spread over more than 12 hours on any day.

Contractor

For & on behalf of SJVN Ltd.

(b) When an adult worker is made to work for more than 9 hours on any day or for more than 48 hours in any week he shall be paid overtime for the extra hours put in by him at double the ordinary rate of wages.

(c) Every workers shall be given paid weekly holiday normally on Sunday. In accordance with the provisions of Minimum wages Central Rules, 1950 as amended from the time to time irrespective whether such workers to be governed by the Minimum wages Act, 1948 or not.

3. Display of Notice regarding wages etc : The contractor shall

(a) Before he commences his work on contract, display and correctly maintain and continue to display and correctly maintain in a clean and legible condition in conspicuous places on the work, notices in English and in the local Indian Language spoken by the majority of the workers giving the rate of wages which has been certified by the Executive Engineer the Chief Executive Officer Regional Labour commissioner, as fair wages and the hours of work for which such wages are earned, and.

b) Send a copy such notice to the certifying officer.

4. Payment of wages : (i) Wages due to every worker shall be paid to him direct.

ii) All wages shall be paid in current coin or currency or in both.

iii) Arrears claimed after 2 months after completion of the work shall not be entertained.

5. Fixation of wages periods : (i) The contractor shall fix the wages periods in respect of which the wages shall be payable.

ii) No wages period shall exceed one month.

iii) Wages of every worker employed on the contractor shall be paid (a) in case of establishments in which wages period in one week within 3 days from the end of the wages period and (b) in the case of other establishments before the expiry of the 7th day from the end of the wages period according as the number of workers employed in such establishment does not exceed 1,000 or exceeds 1,000.

iv) When the employment of any worker is terminated by or on behalf of the contractor, the wages earned by him shall be paid before the expiry of the day succeeding the on which his employment is terminated.

v) All payments of wages shall be made on a working day except when the work is completed before the expiry of the wages period, in which case final payment shall

Contractor

For & on behalf of SJVN Ltd.

be made within 48 hours of the last working day at work site and during the working time.

Note : The term 'working day' means day on which the labour is employed, is in progress.

6. Wage book and wages slip etc : (I) The contractor shall maintain a wage book of each worker in such form as may be convenient at the place of work, but the same shall include the following particulars :
- a) Name of the worker.
 - b) Rate of daily or monthly wages.
 - c) Nature of work on which employed.
 - d) Total number of days worked during each wage period.
 - e) Dates and period for which worked overtime.
 - f) Gross wages payable for the work during each wage period.
 - g) All deductions made from the wage within indications in each case of the for which the deduction is made.
 - h) Wages actually paid for each wage period.
 - i) Signature or thumb impression of the workers.
- (II) The contractor shall also issue a wage slip containing the aforesaid each worker employed by him on the work at least a day period to the day wages.
- (III) The contractor shall issue an Employment Card in the prescribed Form-III to each worker on the day of work on entry into employment. If the worker has already any such card with him from the previous employer, the contractor shall merely endorse that Employment Card with relevant entries. On termination of employment the Employment Card shall again be endorsed by the contractor and returned to the worker.
- (IV) Wage book and wage slip etc : The contractor shall issue an attendance-cum-wage card as per Form-IV to each worker on the day of work or entry into his employment.

Contractor

For & on behalf of SJVN Ltd.

FORM-IV

Attendance :- Cum–wage card

Card No.....Dated.....

Name of contractor.....

Name of worker.....

Name of work.....

Address.....

Designation.....

Rate of wages

Date	Attendance	Signature of person marking attendance	Remarks
------	------------	---	---------

- 1
- 2
- 3
- 4
- 5
- 6
- 7
- 8
- 9
- 10

7. Register of unpaid wages : The contractor shall maintain a register of unpaid wages in such forms as may be convenient at the place of work but the same shall include the following particulars :

- a) Full particulars of the labourers whose wages have not been paid.
- b) Reference number of the muster roll and wages register.
- c) Wage period.
- d) Rate of wages.
- e) Total amount not paid.
- f) Reasons for not making payment.
- g) How the amount of unpaid wages was utilized.
- h) Acquaintance with dates.

Contractor

For & on behalf of SJVN Ltd.

8. Register of accidents : The contractor shall maintain a register of accidents in such form as may be convenient at the work place but the same shall include the following particulars :

- a) Full particulars of the labourers who met with accident.
- b) Rate of wage.
- c) Sex.
- d) Age.
- e) Nature of accident and cause of accident.
- f) Time and date of accident.
- g) Date and time when admitted in hospital.
- h) Date of discharge from the hospital.
- i) Period of treatment and result of treatment.
- j) Percentage of loss of earning capacity and disability as assessed by medical officer.
- k) Claim required to be paid under workmen's Compensation Act.
- l) Date of payment of compensation.
- m) Amount paid with details of the persons to whom the same was paid.
- n) Authority by whom the compensation was assessed.
- o) Remarks.

9. Fines and deductions which may be made from wages :

(i) The wages of a worker shall be paid to him without any deductions of any kind except the following :

a) Fines.

List of acts and omission for which fine can be imposed :

- 1. Willful insubordination or disobedience, whether alone or in combination with another.
- 2. Theft, fraud or dishonesty, in connection with contractors business or property of the SJVN.
- 3. Taking or giving bribes or any illegal gratification.
- 4. Habitual late attendance.
- 5. Drunkenness, fighting, riotous or disorderly or indecent behavior.
- 6. Habitual negligence.
- 7. Smoking near or around the area where combustible or other materials are stacked.
- 8. Habitual indiscipline
- 9. Causing damage to work in progress or to property of the SJVN, the contractor.

Contractor

For & on behalf of SJVN Ltd.

10. Sleeping on duty.
 11. Malingering or slowing down work.
 12. Giving false information regarding name, age father's name.
 13. Habitual loss of wage cards supplied by the employer.
 14. Unauthorized use of employer's property or manufacturing making of unauthorized articles at the work places.
 15. Bad workmanship in construction and maintenance by skilled workers which is not approved by the Deptt. and for which contractors are penalized.
 16. Making false complaints and/or misleading statements.
 17. Engaging in trade within the premises of the establishment.
 18. Any unauthorised divulgence of business affairs of the employer.
 19. Collection or canvassing for the collection of any money within the premises of any establishment unless authorised by the employer.
 20. Holding meeting inside the premises without previous sanction of the employer.
 21. Threatening or intimidating any workman or employer during the working hours within the premises.
- (b) Deductions for absence from duty i. e. from the place or the places where by the terms of his employment he is required to work. The amount of deduction shall be in proportion to the period for which he was absent.
- (c) Deduction for damage to or loss of goods expressly entrusted to the employed persons for custody, or for loss of money or any other deduction which he is required to account where such damage or loss is directly attributable to his neglect or default.
- (d) Deduction for recovery of advances or for adjustment of over payment of wages, Advances granted shall be entered in register.
- (e) Any other deduction which the Central Government or Himachal Pradesh Government or SJVN may from time to time allow.
- ii) No fine should be imposed on any workers save in respect of such acts and omission on his part as have been approved of by the Chief Labour

Contractor

For & on behalf of SJVN Ltd.

Commissioner or any other person authorised by the Himachal Pradesh Government.

- iii) No fine shall be imposed on a worker and no deduction for damage or loss shall be made from his wages until the worker has been given an opportunity of showing cause against such fines or deduction.
 - iv) The total amount of fine which may be imposed in any one wage period on a worker shall not exceed an amount equal to three paise in a rupee of the wages, payable to him in respect of that wages period.
 - v) No fine imposed on any worker shall be recovered from him by instalment or after the expiry of sixty days from the date on which it was imposed.
 - vi) Every fine shall be deemed to have been imposed on the day of the Act or omission in respect of which it was imposed.
10. Register of Fines etc. (i) The contractor shall maintain a register of fines and a register of deductions for damage or loss in forms No. 1 and 2 respectively which should be kept at the place of work.
- ii) The contractor shall maintain both in English and the local Indian Language a list approved by the Chief Labour Commissioner or any other persons authorised by Himachal Pradesh Government clearly stating the act and omission for which penalty of fine may be imposed on a workman and display it in a good condition in a conspicuous place of the work.
11. Preservation of register : The wage book, the wage slips, the register of unpaid wages, the register of accidents, the register of fine, deduction required to be maintained under these regulations shall be preserved for 24 months after the date of last entry made in them and shall be made available for inspection by the Engineer-In-Charge, Labour Welfare Officer or any other officer authorised by the Ministry of W. H. & S. or Himachal Pradesh Government or SJVN in this behalf.
12. Power of labour welfare officer to make investigation enquiry : The labour welfare officer or other person authorised by the Central Government or Himachal Pradesh with a view to ascertaining and enforcing due and proper observance of the fair wage clause and the provisions of these regulations. He shall investigate into any complaint regarding the default made by the contractor sub-contractor in regard to such provision.
13. Report of labour welfare officer : The labour welfare officer or other persons authorized as aforesaid shall submit a report of result of his investigation or enquiry to the Executive Engineer concerned indicating the extent, if any, to which the default has been committed, with a note that necessary deduction from the contractors, will be made and the wages and other dues be paid to the labourers

Contractor

For & on behalf of SJVN Ltd.

concerned. In case an appeal is made by the contractor under clause 14 of these regulations actual payment to labourers will be made by the Executive Engineer after the Regional Labour Commissioner has given his decision on such appeal.

The Divisional Engineer shall arrange payments to the labourers concerned within 45 days from the receipt of the report from the labour welfare officer or the regional labour commissioner as the case may be.

14. Appeal against the decision of labour welfare officer : Any person aggrieved by the decision and recommendations or the labour Welfare Officer or other person so authorised may appeal against such decision to the Regional Labour Commissioner concerned with 30 days from the date of decision. Forwarding simultaneously a copy of his appeal to the Executive Engineer concerned but subject to such appeal, the decision of the officer shall be final and binding upto the contractor.

- 15 Prohibition regarding representation through lawyer :
 - i) A workman shall be entitled to be represented in any investigation or enquiry under these regulations by :
 - a) An officer a registered trade union of which he is a member.
 - b) An officer of a federation of trade unions to which the trade union referred to in clause (a), is affiliated.
 - c) Where the workers is not a member of any registered trade union, by an officer of an registered trade union, connected with or by any other workman, employed in, the industry in which the workers is employed.
 - ii) An employer shall be entitled to be represented in any investigation or enquiry under these regulation by :
 - a) An officer of an associations of employers of which he is member.
 - b) An officer of a federation of associations of employers to which the association referred to in clause (a) is affiliated.
 - c) Where the employer is not a member of any association of employer, by an office of association of employer connected with or by any other employer, engaged in the industry in which the employer is engaged.
 - iii) No party shall be entitled to be represented by legal practioner in any investigation or enquiry under these regulations.

16. Inspection of Books and Slips : The contractor shall allow inspection of the wage books and the wage slip, the register or unpaid wages, the register of accident and the register of fines and deductions to any of his workers or to his agent at a

Contractor

For & on behalf of SJVN Ltd.

convenient time and place after due notice is received or to the labour welfare officer or any other person, authorised by the Central Government or H. P. Govt. on his behalf.

17. Submission of Returns : The contractor shall submit periodical returns as may be specified from time to time.
18. Amendments : The Central/H. P. Government, SJVN may, from time to time, add to or amend the regulations and on any question as to the application, interpretation or effect of those regulation the decision of the Chief Labour Commissioner or Deputy Chief-Labour Commissioner Government of India or any person authorised by Himachal Pradesh Government, SJVN in this behalf shall be final.

Contractor

For & on behalf of SJVN Ltd.

Form -i

Register of fines; regulation 10 (1)

Sl. No.	Name	Father's/ Husband's Name	Sex	Depart. ment	Nature and day of the offence for which fine imposed	Whether workman showed caused against fine or not, if so, enter date	Rate of wages of	
1	2	3	4	5	6	7	8	9
	10	11						

Contractor

For & on behalf of SJVN Ltd.

Form -ii
 regulation 10 (1)

Register of Deductions for Damages or loss caused to the
 employer by the neglect or default of the employed persons.

Sl. No.	Name of workman	Father's/ Husband's Name	Sex	Department	Damage or loss caused with date	Whether and showed deducti- ons	Date instal- on amount of deduc- tions	
1	2	3	4	5	6	7	8	9
	10	11						

Contractor

For & on behalf of SJVN Ltd.

Form -iii
employment card regulation 6 (iii)

Name and sex of the
worker.....

Age or date of
birth.....

Father's Name..... Indent faction
mark.....

Address.....
.....

Particulars of next of his kin (wife and children, if any) or of dependent next of kin, in case
the worker has no wife and child.

Name.....
.....

.....
.....

Full address of department (specify village, district and state)

Sl. No.	Name & address of employer (specify whether a contractor or sub contractor)	Particulars of work site and description of work done	Total period for which the worker is employed (from-to)	Actual number of days worked	Leave taken (number of days specified)
1	2	3	4	5	6

Give SI. No. Remarks	Nature of Sign of as on reverse period wise	Wage period work done	Wage rate	Total wage (with		
7	8	9	10	11	12	13
			particulars of unit in case of piece work)	worker during the period shown under column (5)		

Contractor

For & on behalf of SJVN Ltd.

N. B. If the worker is employed both in piece and the rate, relevant entries in each case should be made separately

Responsibilities under contract labour
(regulation and abolition) act 1970
Licensed Contractor

(1) It should be ensured that no contractor be engaged for undertaking any work through contract labour unless a Licence has been obtained by such contractor from the Labour Department (State) in requisite Form. This is also applicable to the sub-contractors engaged in the establishment.

(2) Form of certificate of principal employer needs to be issued duly signed by the principal employer as declared in the Registration Certificate in Form-V. As regarding issuance of such Certificate in respect of sub-contractor signature of the contractor recommending such issuance should be obtained. The contractor while issuing such recommendation should clearly state that he shall be bound to follow provisions of the Act and rules framed therein and shall be liable for any default on the part of such sub-contractor. It should be ensured that the no. of sub contractors to be engaged are kept minimum.

(3) The Nodal Officer of the HR Department should maintain a register duly endorsing the details of the contractor and the Licence No., periodicity etc. and ensure that the Licence is renewed before its expiry.

Welfare And Health Of Contract Labour

(1) The provisions of the contract Labour Act with respect to the aforesaid provisions should be clearly brought to the knowledge of the principal contractor and the sub contractor in respect to maintenance of canteen, rest room, facility of wholesome drinking water, first aid facility etc. and ensure that the same is being properly maintained so as to avoid any liability of principal employer on such account. The site in-charge should be informed about the above so that the same is monitored by him or his authorized representative.

Responsibilities For Payment Of Wages

(1) As per the provisions of the Act contractor is responsible for disbursing wages to each worker employed by him before expiry of 7th day of the month.

(2) The Engineer-in-Charge shall nominate a representative duly authorized by him to be present at the time of disbursement of wages by the contractor every month. The authorized representative of the EIC shall record under his signature a certificate at the end of the entries in the register of wages in the following form

(i) "Certified that the amount shown in Column No. _____ has been paid to the _____ workman concerned in _____ my presence on _____ at _____

Contractor

For & on behalf of SJVN Ltd.

(3) It should be clearly understood that in case the contractor fails to make payment of wages within the prescribed period or make short payment then the principal employer shall be liable to make payment and wages in full or the unpaid balance to the contract labour employed by the contractor. However, such amount shall be recoverable from the contractor from any amount payable to the contractor under any contract.

Maintenance of Registers and other records.

Registers to be maintained by the principal employer

Register of contractors in form-XII.

Registers to be maintained by the contractor.

- (1) Register of persons employed in Form XIII.
- (2) Muster Roll and Register of Wage in Form XVI, and Form XVII. Register of deductions for damage or loss, Register of fines and Register advances in Form XXI and XXII respectively.
- (3) Register of overtime in Form XXIII.
All registers and other records required above shall be maintained complete and up to date and available in English or Hindi.
- (4) Where no deduction or fine has been imposed or no overtime has been worked during the wage period a nil entry shall be made across the body of the register at the end of the wage period.
Employment Card

Every Contractor is required to issue an Employment Card within three days of employment to contract labour.

Notices

- (1) Notices showing register of wages, hours of work, wage periods, dates of payment of wages, names and address of the inspectors having jurisdiction should be displayed in English and Hindi at the establishment site by the principal employer/contractor.
- (2) The principal employer or the contractor shall display the abstracts of the Act and rules in English and Hindi.
Returns
- (1) It may be ensured that every contractor including sub-contractor sends half yearly return in Form XXIV (in duplicate) to the Licence Officer not later than 30 days from the closure of the half year.
- (2) It should be ensured that the principal employer sends annual return in Form XXV so as to reach the registering officer concerned not later than the 15th February following the end of the year to which it relates. Collection of data and sending return will be the responsibility of the HR Department.

Contractor

For & on behalf of SJVN Ltd.

Inspections

- (1) Representative of HR Department should inspect the records of the establishment of the contractor once in three months to ensure the compliance of the provisions for contract labour (R&A) Act/rules. A schedule for inspection may be prepared and finalized in consultation with the Engineer-in-Charge.

Responsibilities under inter state migrant workmen act 1979 and rules framed there in.

- (1) The principal employer to which the provision of the Act applies is required to obtain registration certificate from the registering officer under the Act.

- (2) The contractors engaging inter state migrant workmen are required to obtain separate Licence under the Act employing five or more inter state migrant workmen.
Duties and Obligations of Contractor

- (1) Every contractor engaging inter state migrant workmen are required to furnish Return in form X to the State Labour Department with a copy to the principal employer.

- (2) Every contractor shall issue to every inter-state migrant workman a Pass Book in fixed with their passport size photograph for their workmen in Hindi containing the following details.

- (i) Date of recruitment;
- (ii) Date of employment;
- (iii) The name and place of the establishment wherein the workman is employed;
- (iv) The period of employment;
- (v) The proposed rates and modes of payment of wages;
- (vi) The displacement allowance payable;
- (vii) The return fare payable to the workman on the expiry of the period of his employment and in such contingencies as may be prescribed and in such other contingencies as may be specified in the contract of employment;
- (viii) Deduction made; and
- (ix) Name and address of the next kin of migrant workman;
Displacement Allowance

Contractor

For & on behalf of SJVN Ltd.

(1) The contractor shall pay Displacement Allowance at the time of recruitment to each workman equal to 50% of the monthly wages payable to him in addition to the normal wages which shall not be refundable.

Journey Allowance

(1) A Journey Allowance of a sum not less than the fare from the place of residence of the inter-state migrant workman in his state to the place of work shall be payable by the contractor for both outward and return journeys including wages for such journey.

Other facilities

The contractor is liable to provide the following :

- (1) Provide and maintain suitable accommodation during the period of their employment.
- (2) Provide medical facilities free of cost for treatment of ailment of self and any member of his family may suffer during the employment including hospital charges, travel expenses for the patient from place to his her residence to the hospital and back.
- (3) Contractor shall provide protective clothing to the workmen including woolen clothing's before onset of winter season of the area.
- (4) In case of fatal accident or serious bodily injury to any such workman, the contractor shall promptly report to the State Authorities and also to the next kin of the workman.

Responsibilities for Payment of Wages

The provisions as per Contract Labour Act shall be applicable. However, in addition to the same other payments as per the provisions of the Act as mentioned above shall have to be ensured by the principal employer. The provisions of welfare and health of the contract labour as per the provisions of the Contract Labour Act shall also be applicable to the inter-state migrant workmen.

Maintenance of Registers and Records

Every principal employer shall maintain register of contractors in Form-XII.

Contractor

Every contractor shall maintain register of persons employed in Form-XIII, displacement-cum- outward journey allowance register in Form XV and XVI.

Returns

Periodical returns, display of abstracts of the rules, notices etc. as per the Contract Labour Act and rules shall also be followed in this case.

Responsibilities under workmen compensation act 1923

(1) Principal employer shall ensure Notification of Commissioner for workmen compensation by the State Government. The liabilities under the Act including payment of

Contractor

For & on behalf of SJVN Ltd.

compensation etc. shall be clearly brought to the notice of the contractor including sub contractor at the commencement of the contract.

(2) It should be ensured that the compensation in case of fatal accident as well as non fatal accident to any contract labour arising out of and during the course of employment is deposited with the Commissioner as per the provisions of the Act immediately.

Report of fatal accident and serious bodily injuries

(1) In case of fatal accident and any serious injury occurring in the premises of the establishment report may be sent to the Commissioner, Inspector of Factories (State), Chief Medical Officer and other authorities under the Act including CMD and Directors.

(2) An inquiry may be conducted by the Safety Officer and other member to be associated as per the approval of the head of the establishment to inquire into the cause of accident and suggest remedial measures to avoid recurrence of such accidents.

Returns

(1) It should be ensured that the principal employer/contractor engaging the contract labour submits annual returns in terms of the schedule every year to the authority as notified from time to time.

Safety and Health

It shall be the endeavor of principal employer to ensure as far as reasonably practical health and safety of all contract labours working in the project/factory. The objective should be to develop safety consciousness among all employees including contract labour. The basic motto should be to bring about improvement in the overall work environment by timely monitoring and having adequate control in operation resulting in the reduction in accidents.

The contract provision regulating the Health and Safety aspect shall be closely coordinated by the Safety Officer as well as the in-charge of Safety in respect of Contractor's establishment. The Safety Officer shall conduct regular monitoring of Health and Safety aspects and conduct Safety Committee Meetings as well as Safety Audit. The contents of the Safety Assurance Plan which forms part of the agreement shall be complied with.

Responsibilities under Minimum Wages Act 1948

(1) It has to be ensured by the principal employer that the wages paid by the contractor to its labours are as per the wage formula including DA differential in terms of the contract provisions laid down in the contract.

(2) In no case such wages should be less than the minimum wage prevailing in the State for such scheduled employment and as revised from time to time.

(3) The Engineer-in-Charge or his representative while certifying the wages being disbursed by the contractor in his presence should verify the same.

Responsibilities under Employees Provident Fund and Miscellaneous Provisions Act 1952

Contractor

For & on behalf of SJVN Ltd.

- (1) It has to be ensured by the principal employer that the contractor including the sub contractor obtains independent PF Code from the office of RPFC, Shimla before engaging contract labour.
- (2) Deductions in terms of the provisions of EPF Act 1952 should be made from the wages payable to the contract labour.
- (3) Matching contribution equal to the contribution/deduction made from each contract labour should be made by the contractor and deposited with the RPFC, Shimla every month.
- (4) A copy of the PF monthly return submitted to the RPFC should be obtained from each, contractor by the Nodal HR Officer.
- (5) It should be ensured by the principal employer that the register and records be maintained by the contractor under the EPF Act 1952 is maintained properly and be inspected accordingly.

Inspection

Representative of HR Department should carryout inspection of the contractor's establishment once in three months or on lesser frequency as need be to ensure compliance of the labour laws.

An inspection report may be prepared bringing out details of deviation/violation. Such report should be submitted to Project-in-Charge with a copy to CC and contractor.

Contractor

For & on behalf of SJVN Ltd.

DRAWINGS

Contractor

For & on behalf of SJVN Ltd.

1

2

3

4

5

VIEW-D

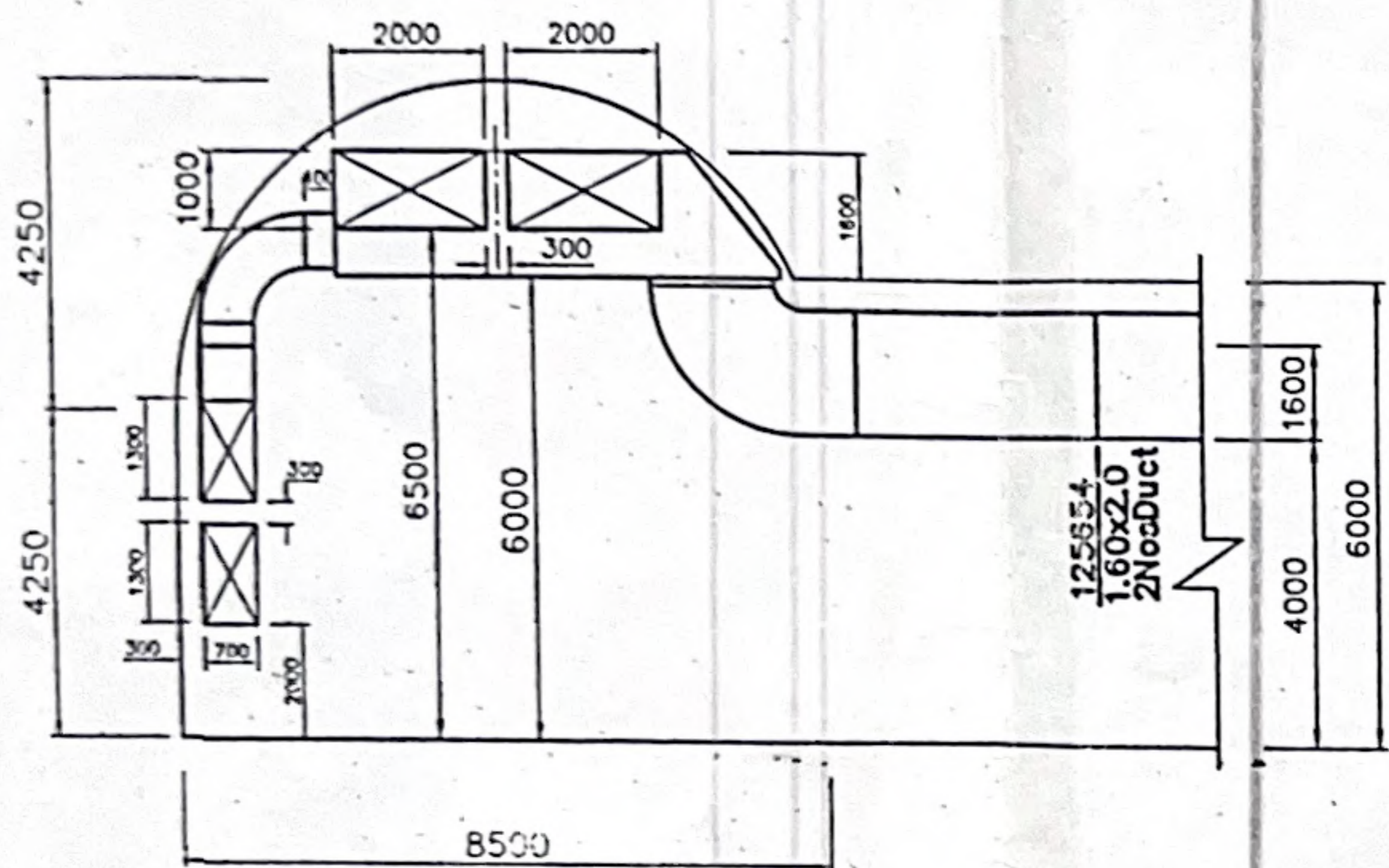

SECTION AT C-C

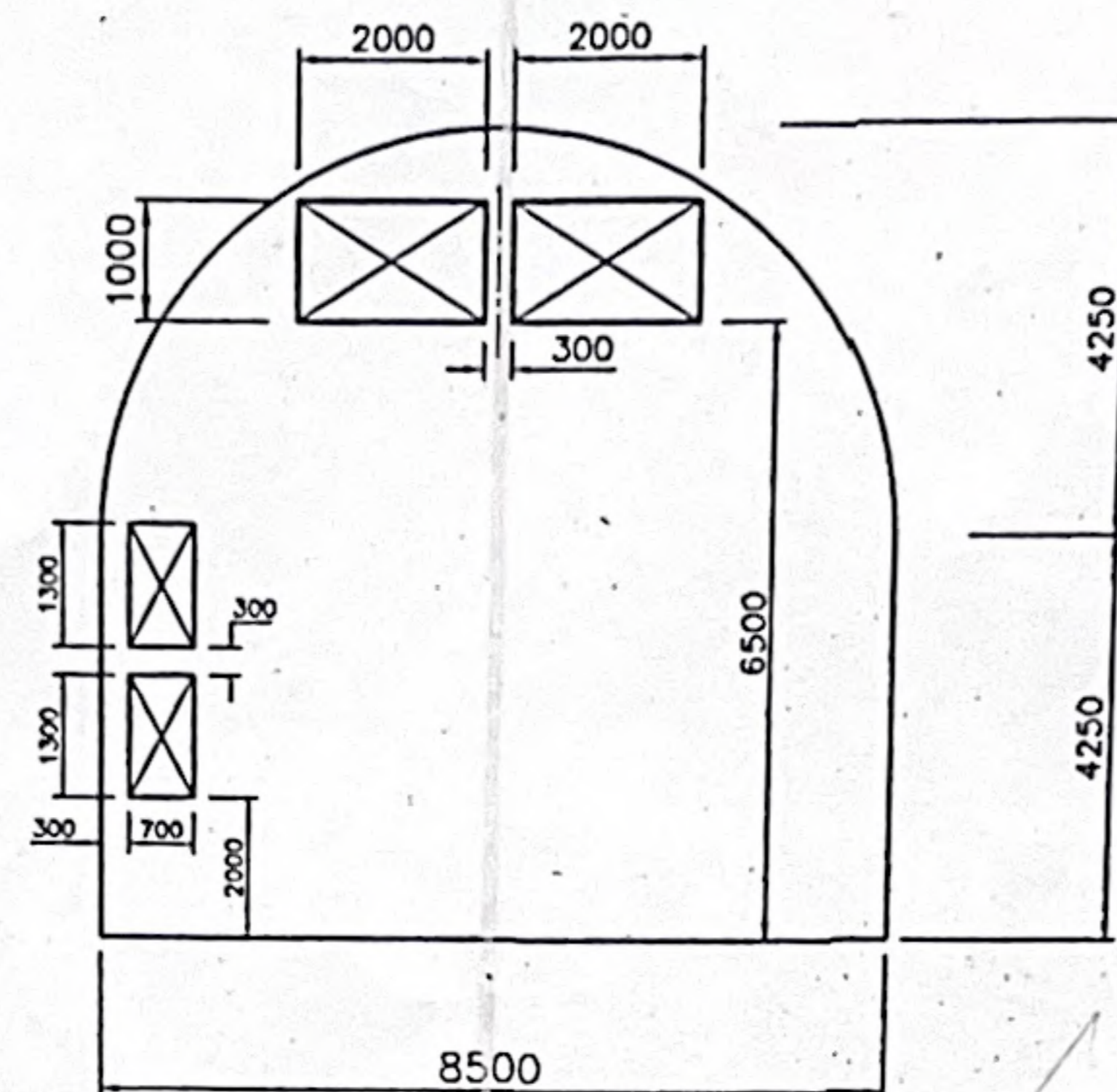

SECTION AT B-B

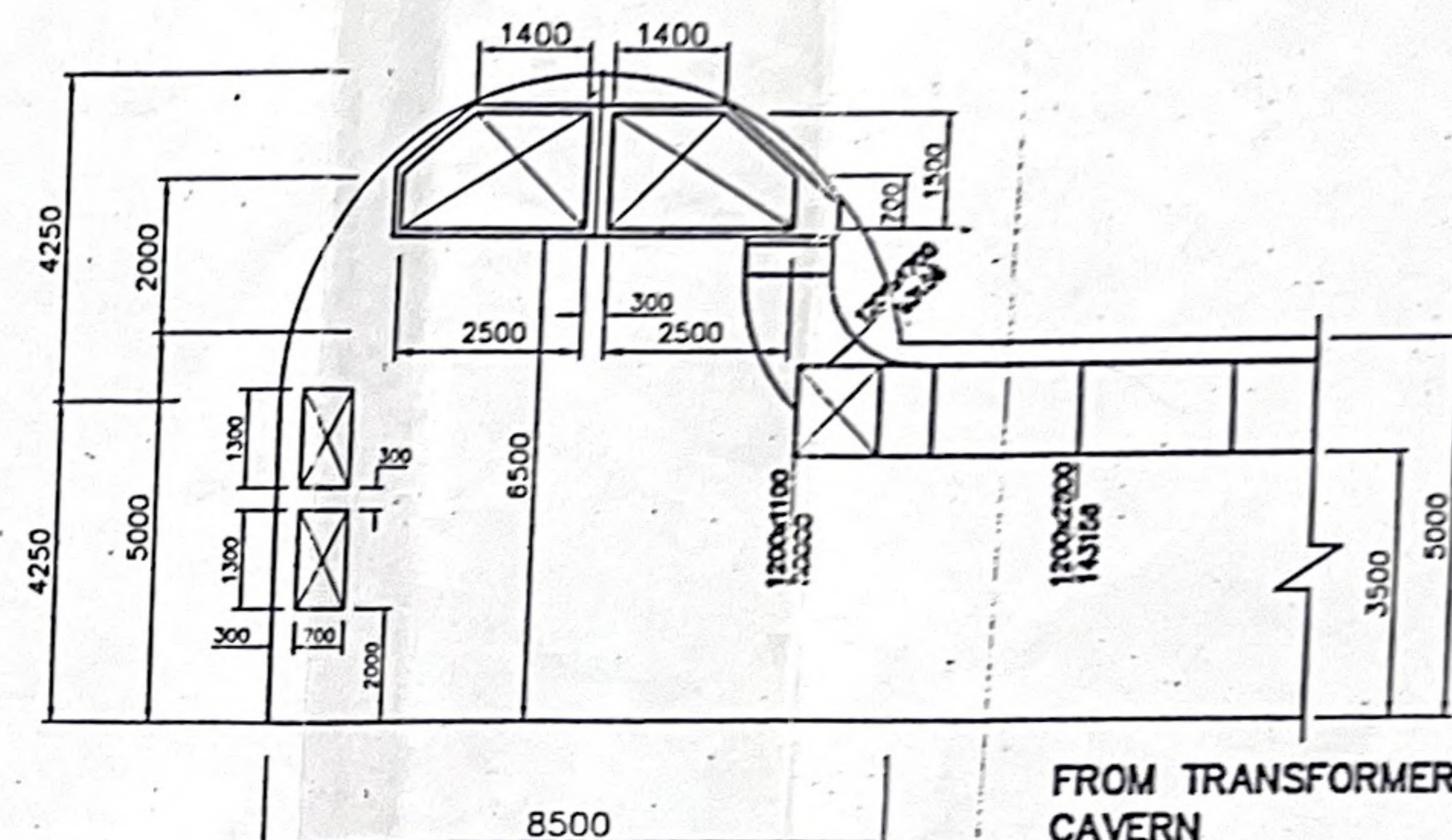

SECTION AT A-A

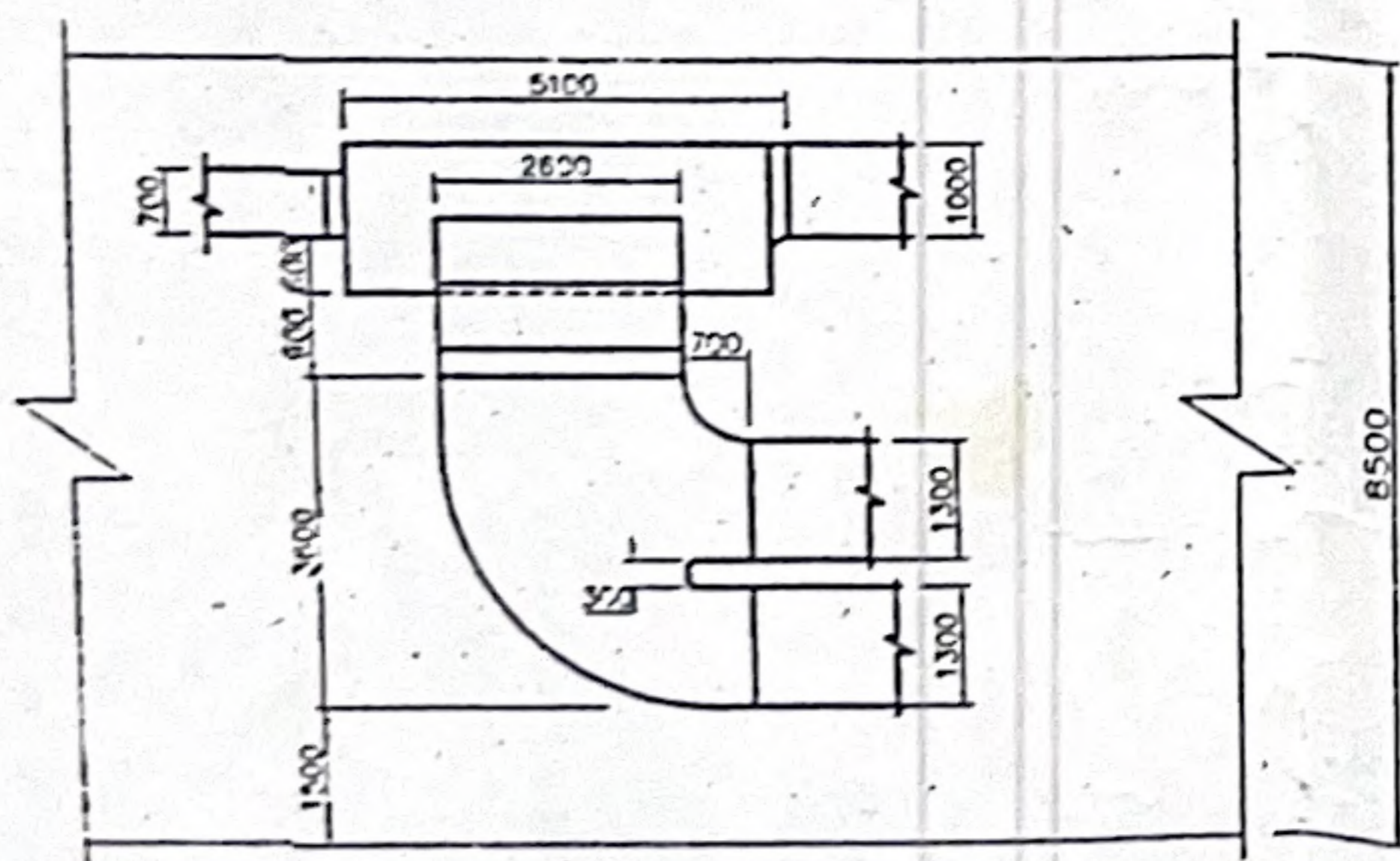

DETAIL OF DUCT AT VIEW-D

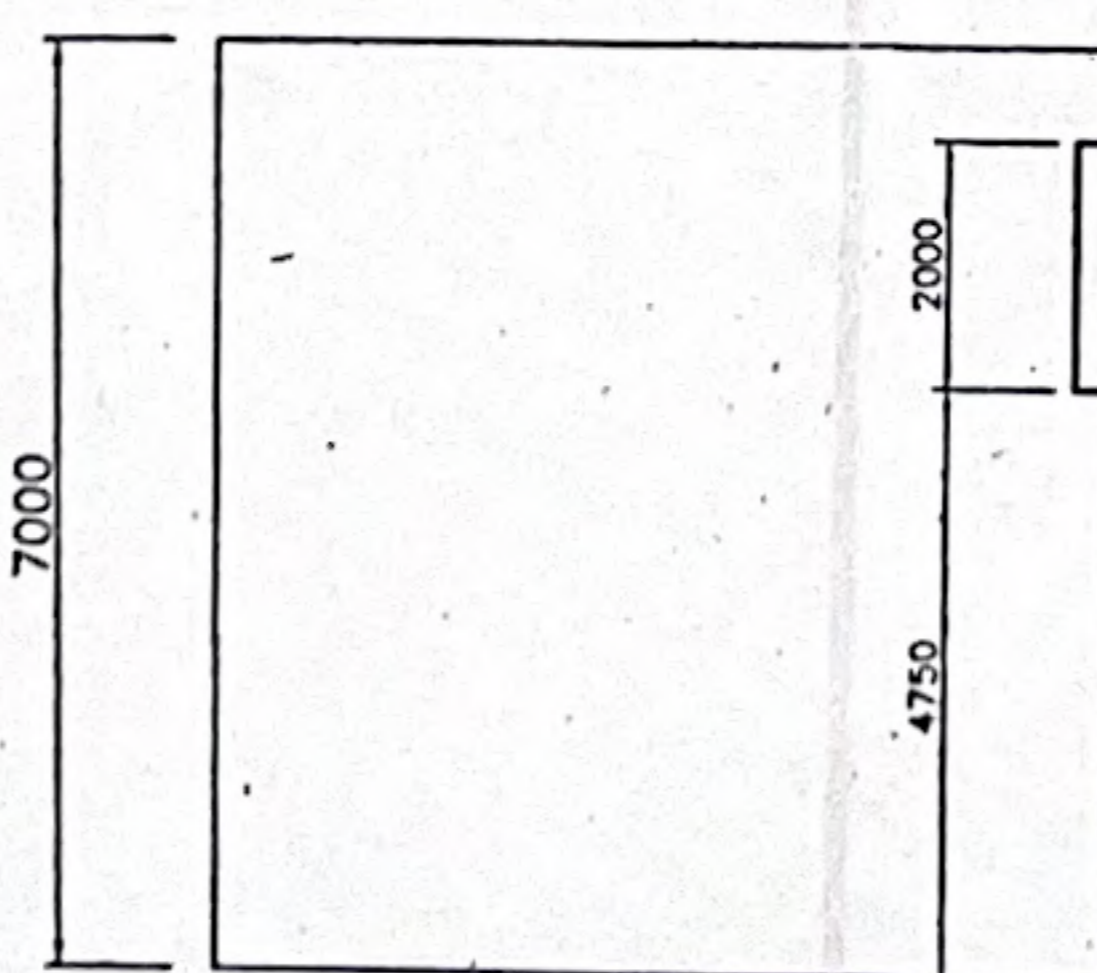

BLOWER ROOM

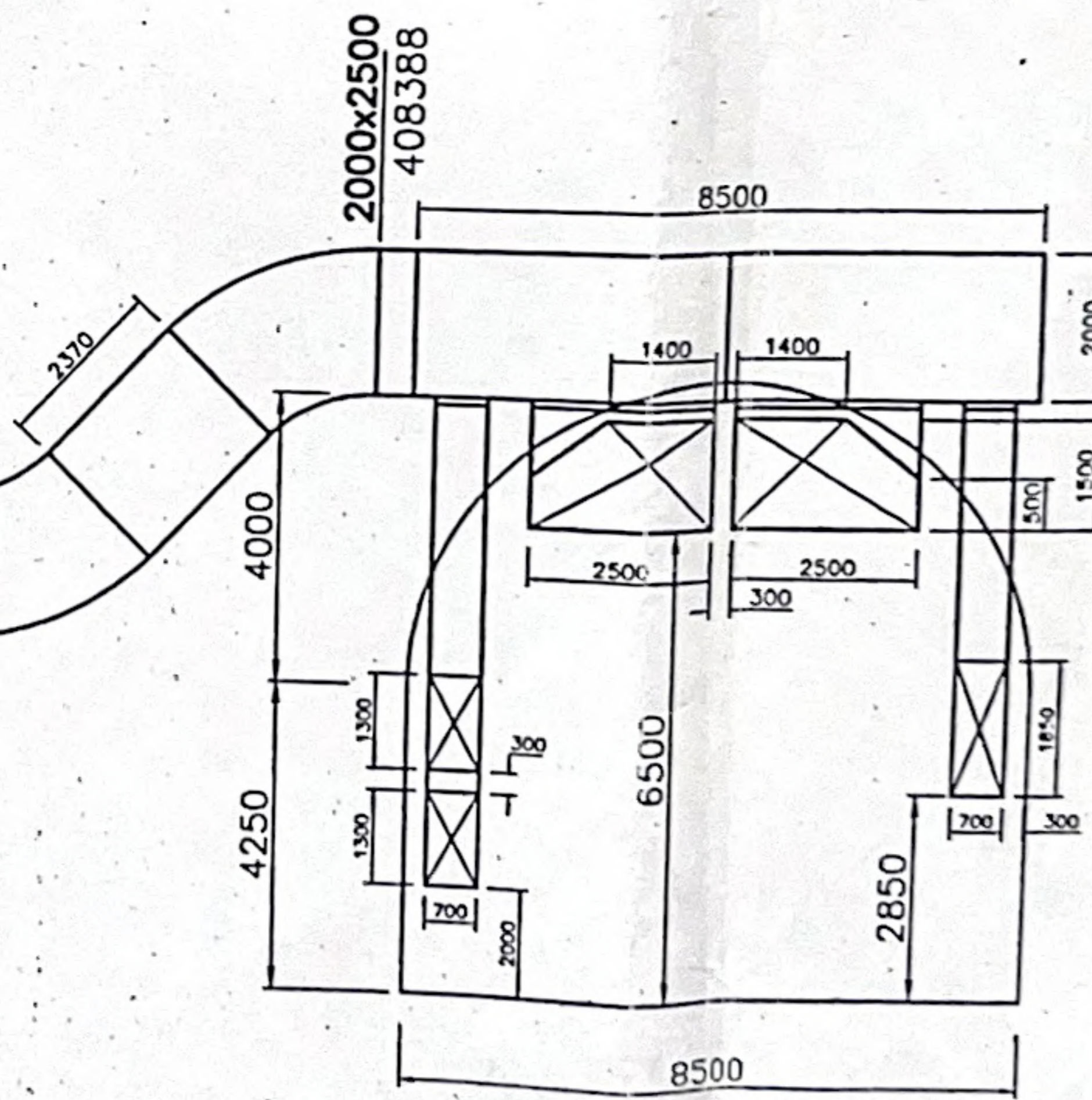

DETAIL OF VIEW-XX

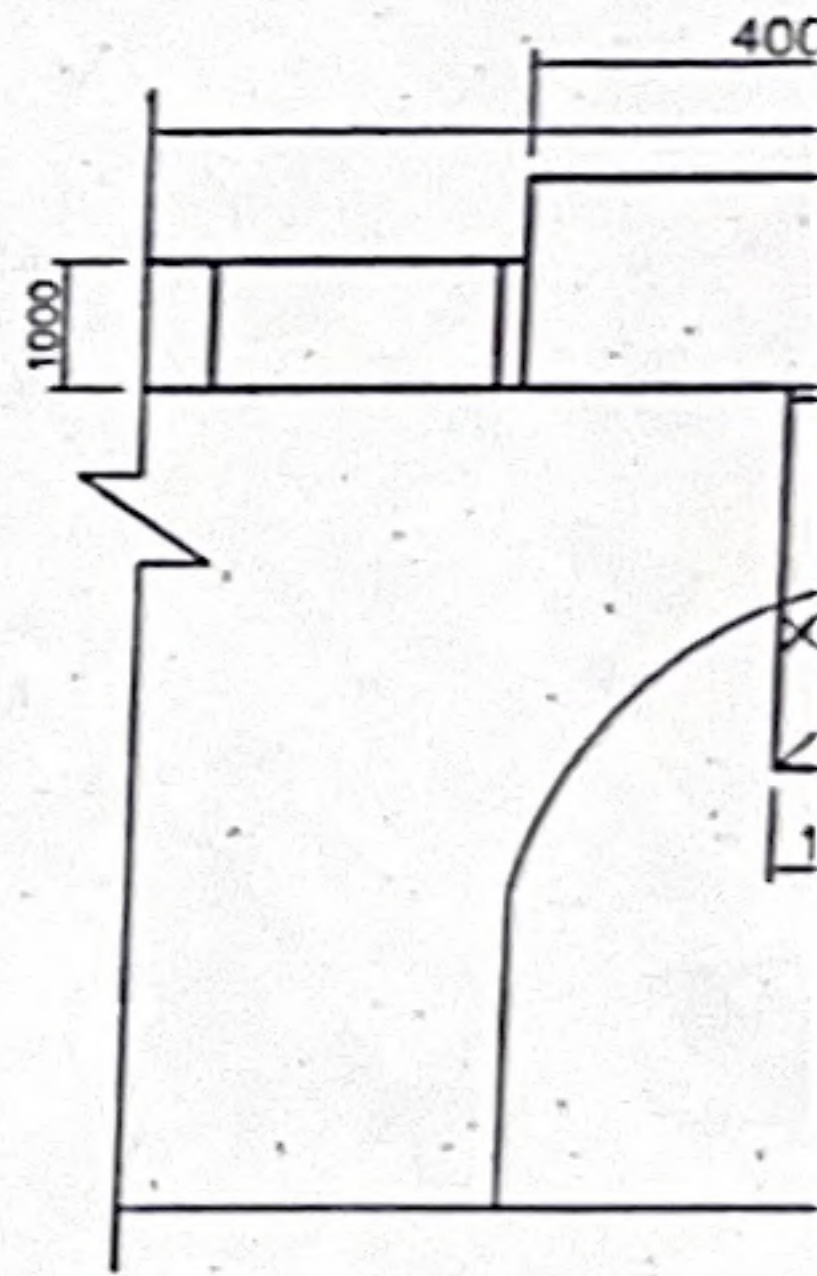

DETAIL C

6

7

8

RevNo Revision note

Date

Signature

Checked

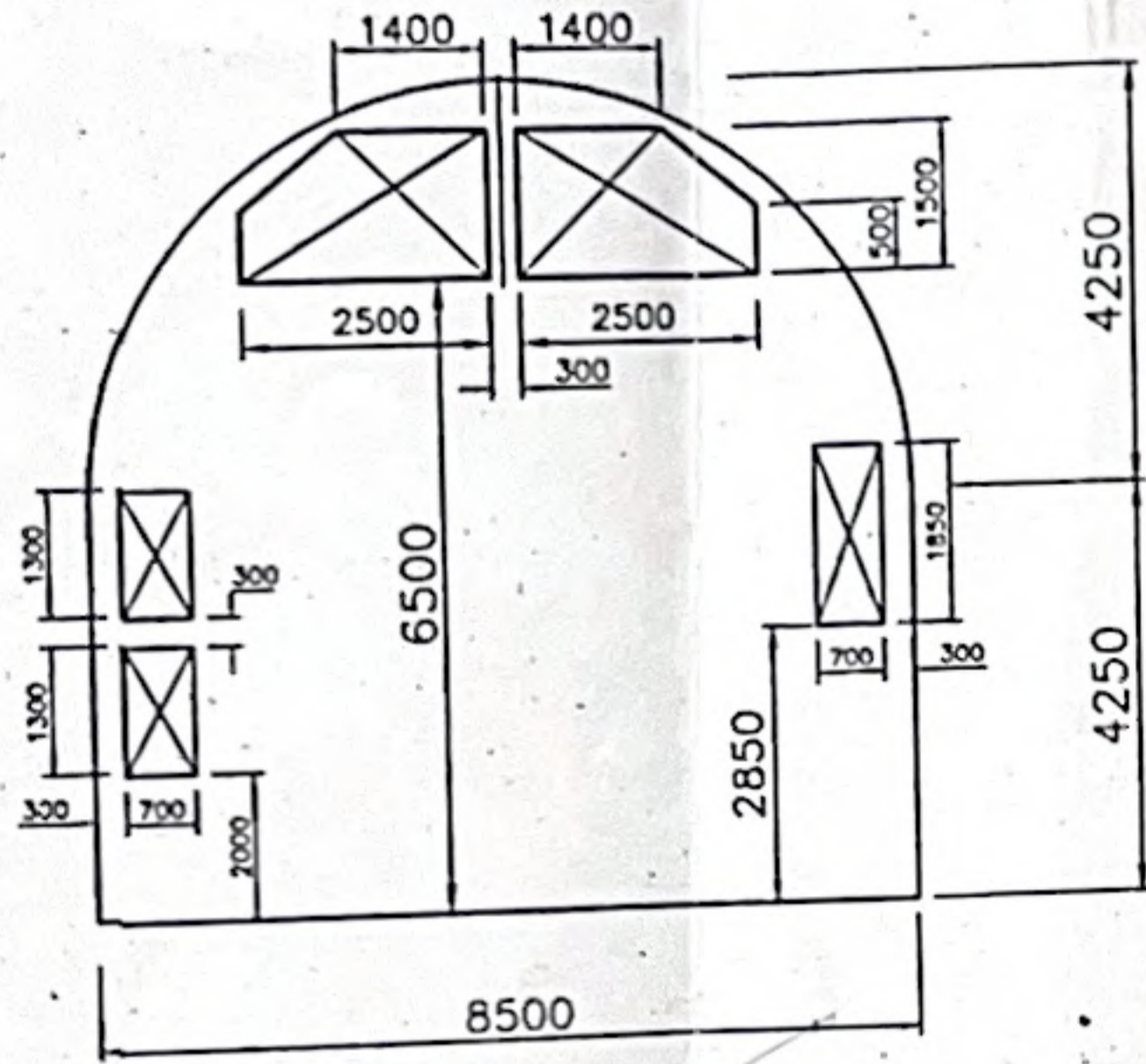

SECTION AT X-X

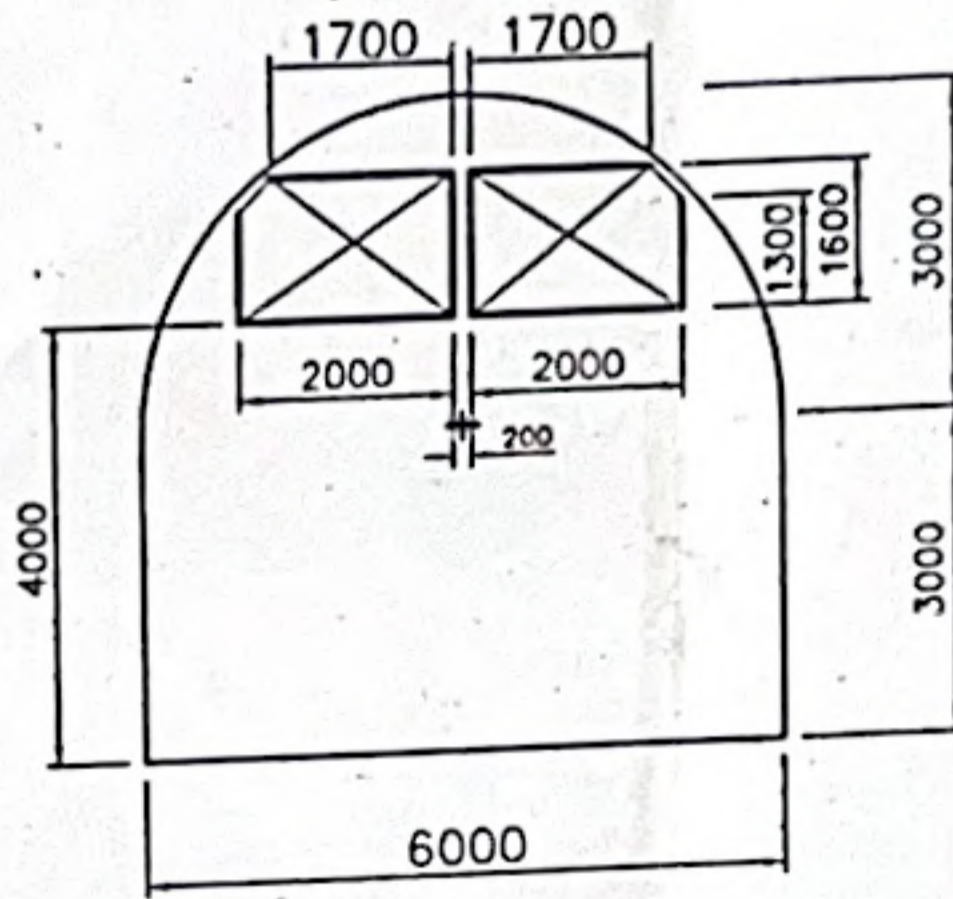

SECTION AT Y-Y

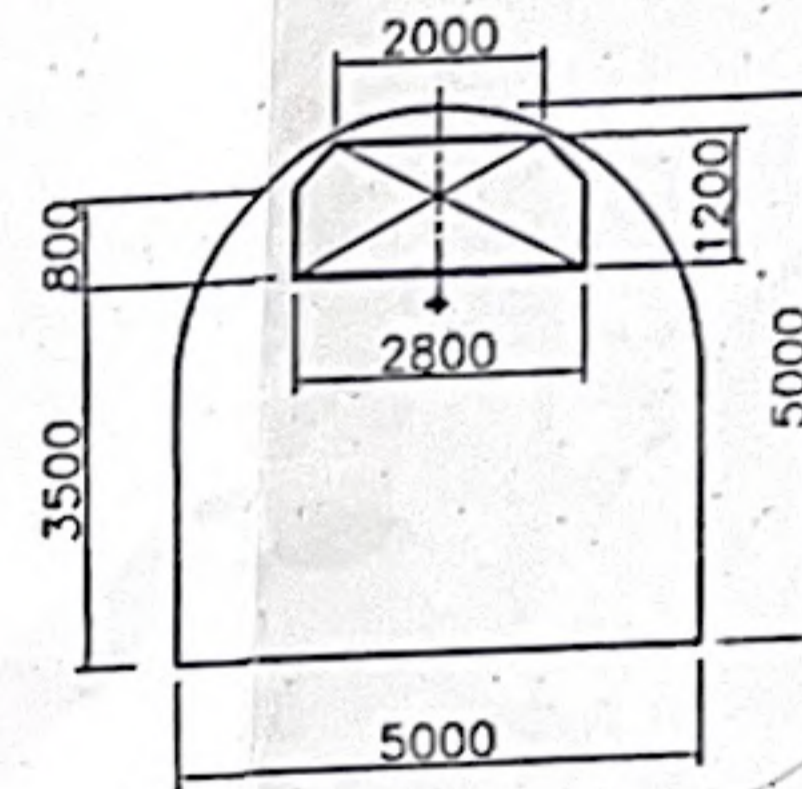

SECTION AT Z-Z

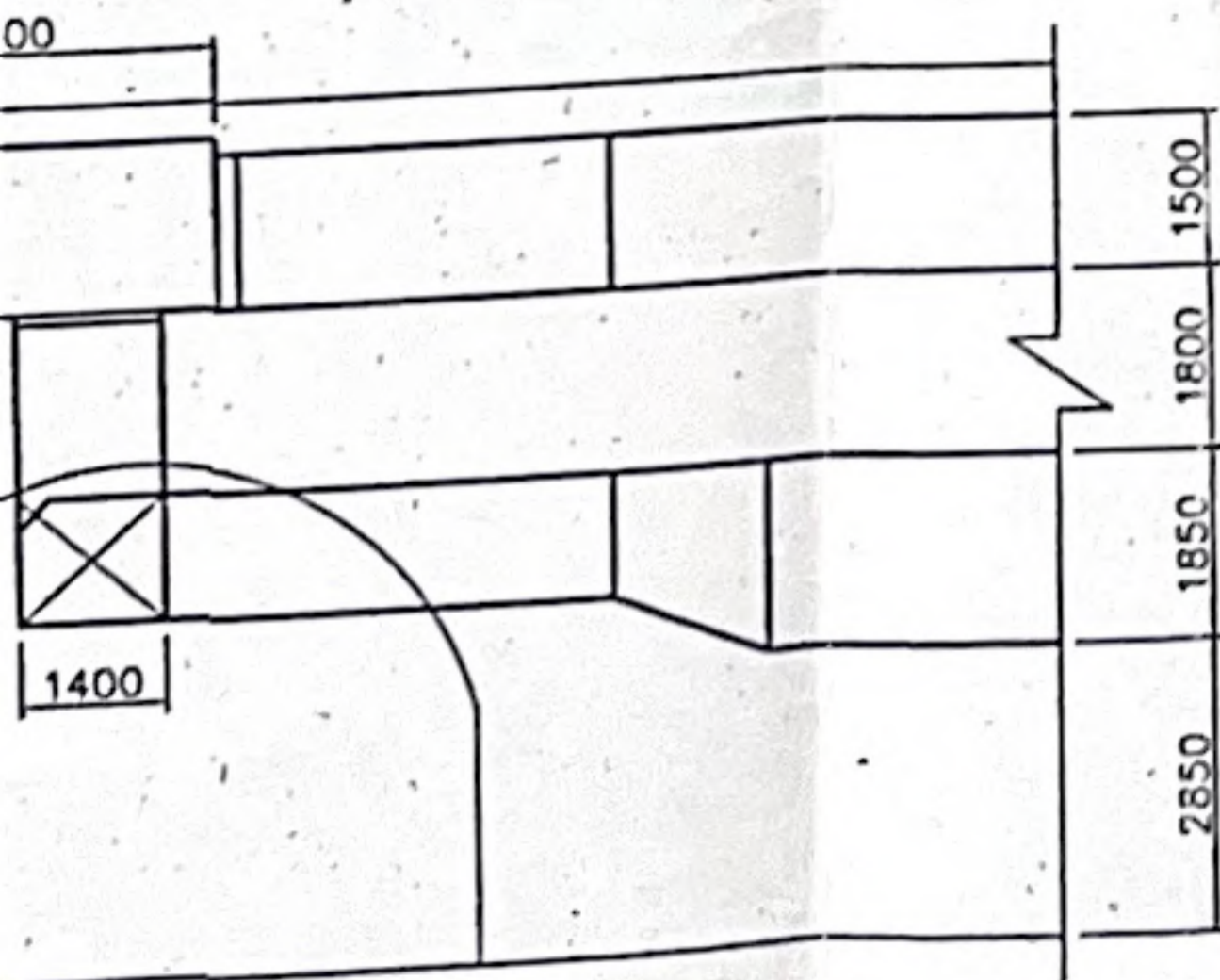

OF DUCT AT VIEW-E

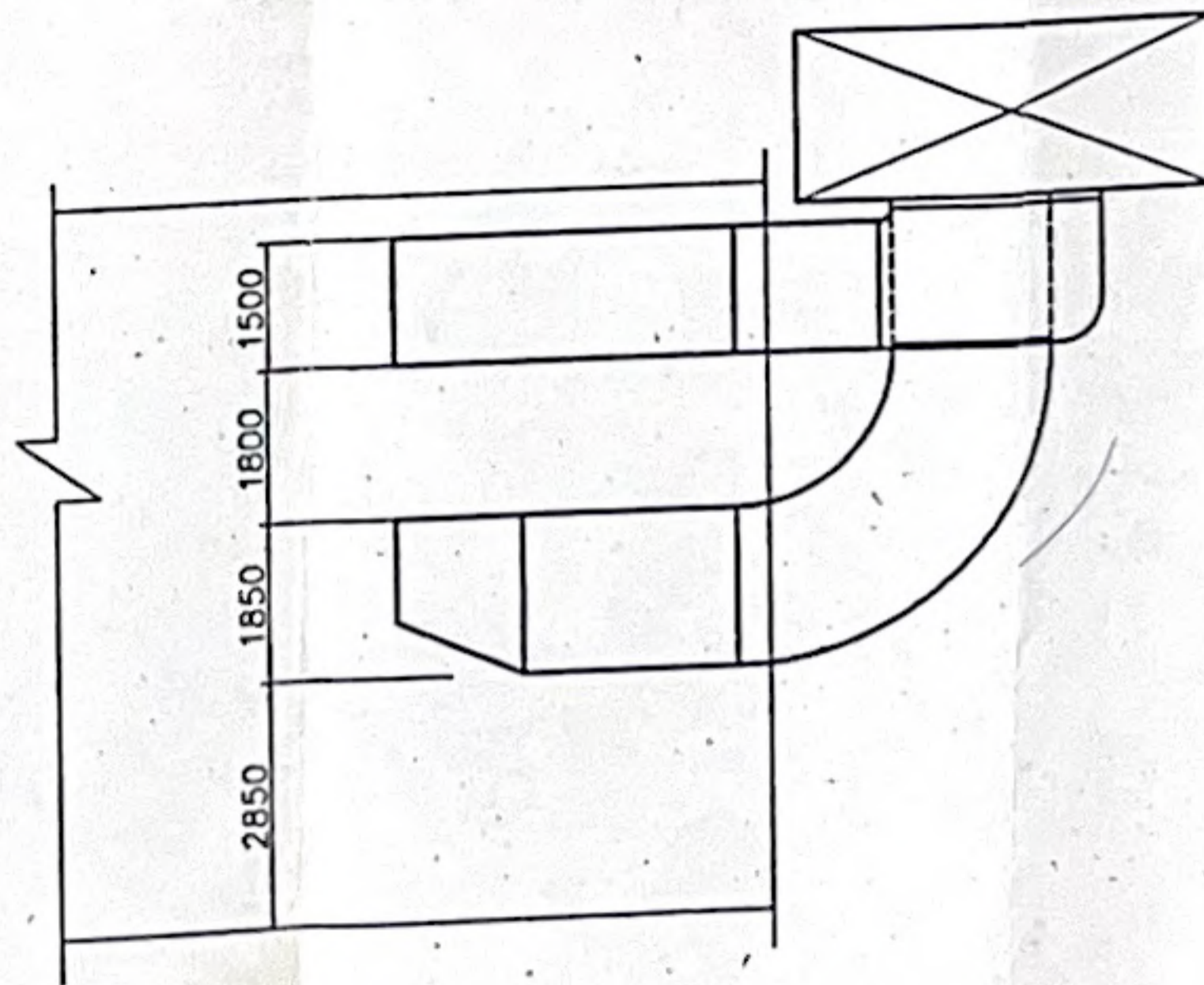

SECTION-MM

A

B

C

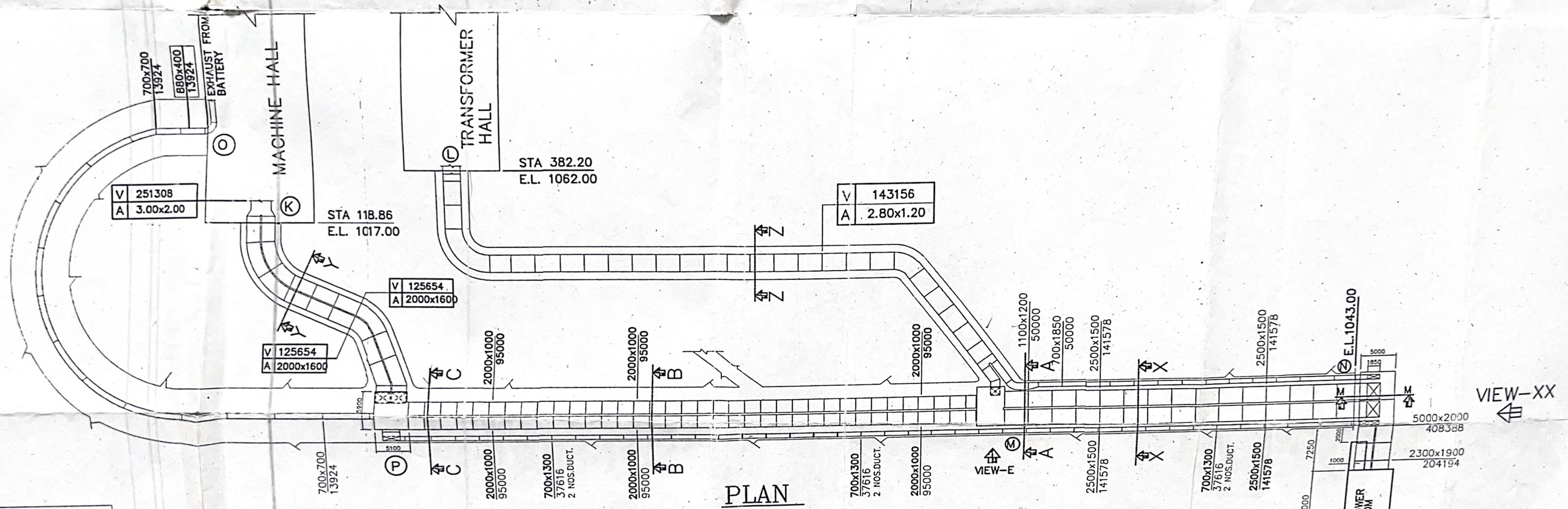

PLAN

LENGTH OF EXHAUST DUCTING

FROM	TO	DISTANCE IN MTRS.
K	M	452.36
L	M	382.00
M	N	137.50
O	P	246.00
K	P	113.00

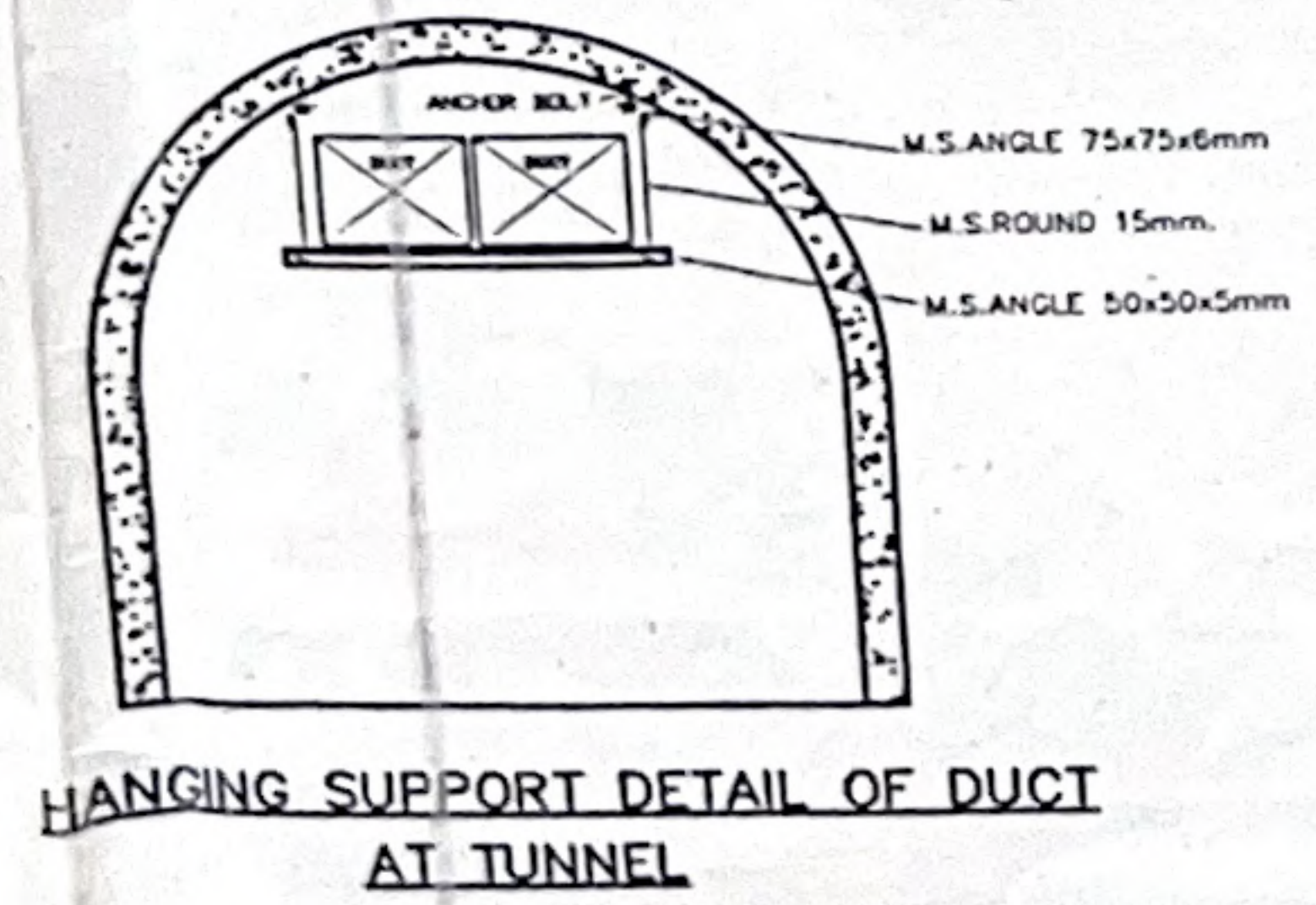
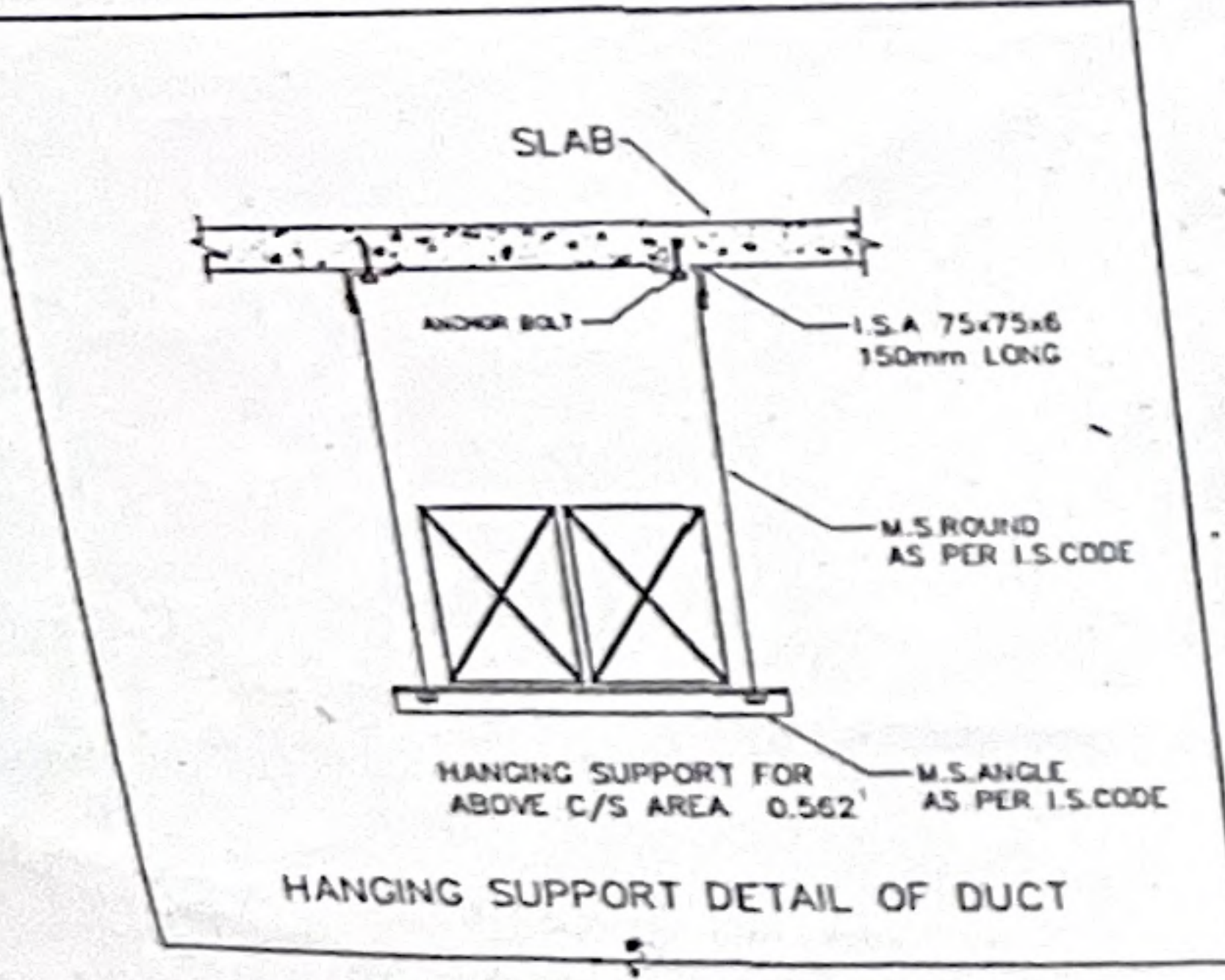

CUSTOMER: **SJVN Limited**

PROJECT: **AIR CONDITIONING**

MODEL NO:

" This design and drawing is not given or sold but loaned it remains the property of S.R.Paryavaran Engineers (P) Ltd. Panchkula and subject to their recall. It is confidential and must not be made public or copied reproduced without previous written permission."

TITLE: **DETAIL OF EXHAUST**

NOTE :-

0.1 ALTERATION IN DUCT ROUTING & SIZES WHEREVER NECESSARY AS PER SITE CONDITIONS SHALL BE CARRIED OUT AT THE TIME OF ERECTION & FABRICATION IN CONSULTATION WITH E.I.C.

0.2 FOR B.O.Q. REFER SEPERATE PART DRAWINGS .

0.3

WHEREVER REQUIRED REFER TO THE FOLLOWING CODE TO BE FOLLOWED FOR THICKNESS OF G.P. SHEET FOR RECTANGULAR DUCT CONSTRUCTION		
MAXIMUM SIZE	THICKNESS OF G.P. SHEETS/mm	BRACING
UP TO 300	0.63	NONE
301 TO 600	0.63	NONE
601 TO 750	0.63	25 X 25 X 3 mm ANGLES, 1.2 m FROM JOINT.
751 TO 1000	0.80	25 X 25 X 3 mm ANGLES, 1.2 m FROM JOINT.
1001 TO 1500	0.80	40 X 40 X 3 mm ANGLES, 1.2 m FROM JOINT.
1501 TO 2250	1.00	40 X 40 X 3 mm DIAGONAL ANGLES, or 40x40x3mm, ANGLES, 60 cm FROM JOINT.
2251 AND ABOVE	1.25	40 X 40 X 3 mm DIAGONAL ANGLES, or 40x40x3mm, ANGLES, 60 cm FROM JOINT.

0.4 FIRE DAMPER DETAILS & LOCATION TO BE DECIDED & SUBMITTED SEPERATELY.

0.5 ALL DIMENSIONS ARE IN MM.

VIEW-XX



10x2000
408388

00x1900
204194

CUSTOMER: **SJVN Limited .**

PROJECT: **AIR CONDITIONING AND VENTILATION**

DATE: 13-3-2010

MODEL NO:

MATERIAL SIZE:

SCALE: NTS

" This design and drawing is not given or sold but loaned it remains the property of S.R.Paryavarani Engineers (P) Ltd. Panchkula and subject to their recall . It is confidential and must not be made public or copied or reproduced without previous written permission."

DRAWN

Sanjeev

ENGRS. AND CONS.

CHECKED

M. Kapila



S.R. PARAYAVARAN ENGINEERS PVT.LTD.

DESIGNED

H.GUPTA

70. Industrial Area, Phase-I
Panchkula - 134 113 (INDIA)

APPROVED

TITLE:

DETAIL OF EXHAUST DUCT AT M.A.

DRG NO.

SRP-SJVNL-03-2010-1177

SHEET:

REV:

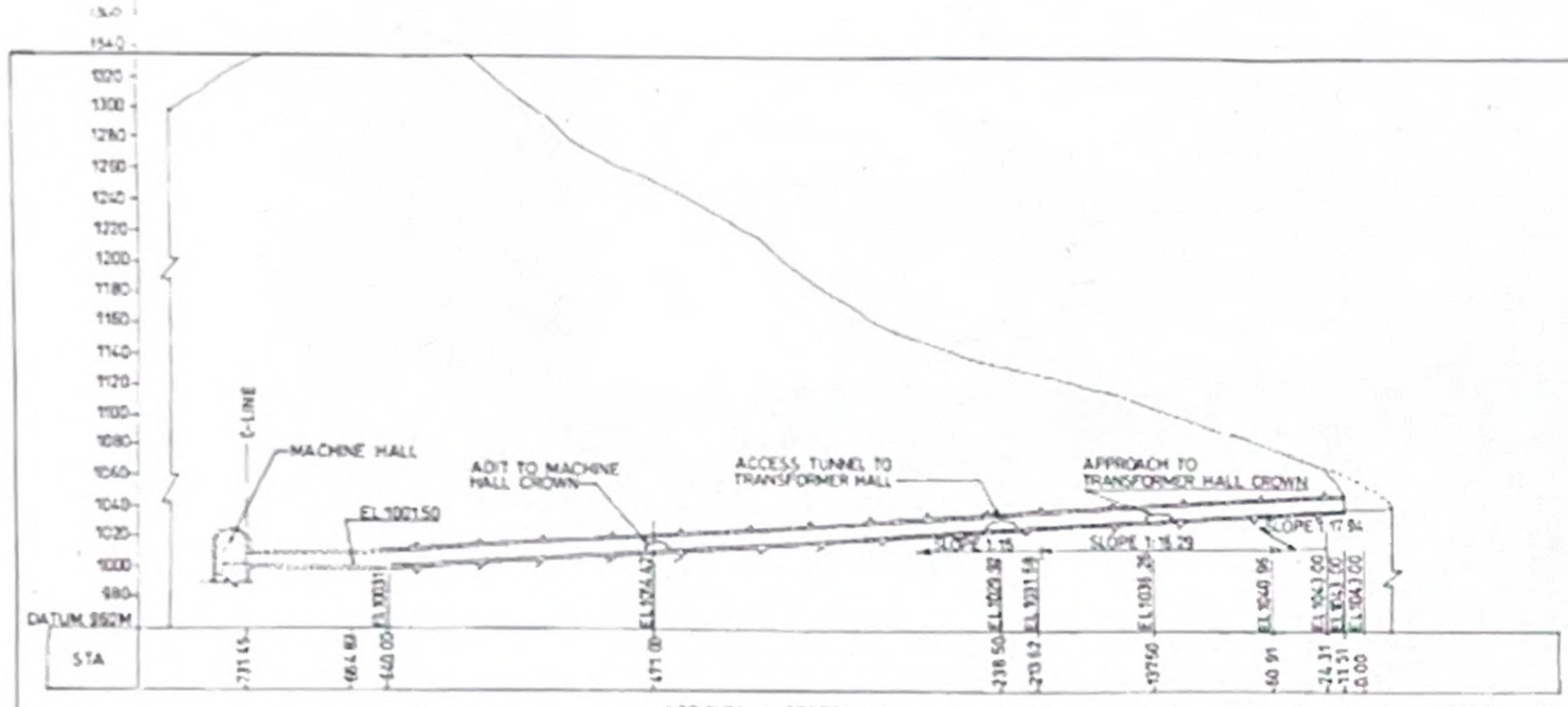

- NOTES:-
1. ALL DIMENSIONS ARE IN MILLIMETRES, STAS AND ELEVATIONS IN METRES UNLESS OTHERWISE SPECIFIED.
 2. NO DIMENSION SHALL BE SCALED OUT ONLY WRITTEN DIMENSIONS SHALL BE TAKEN AS CORRECT.

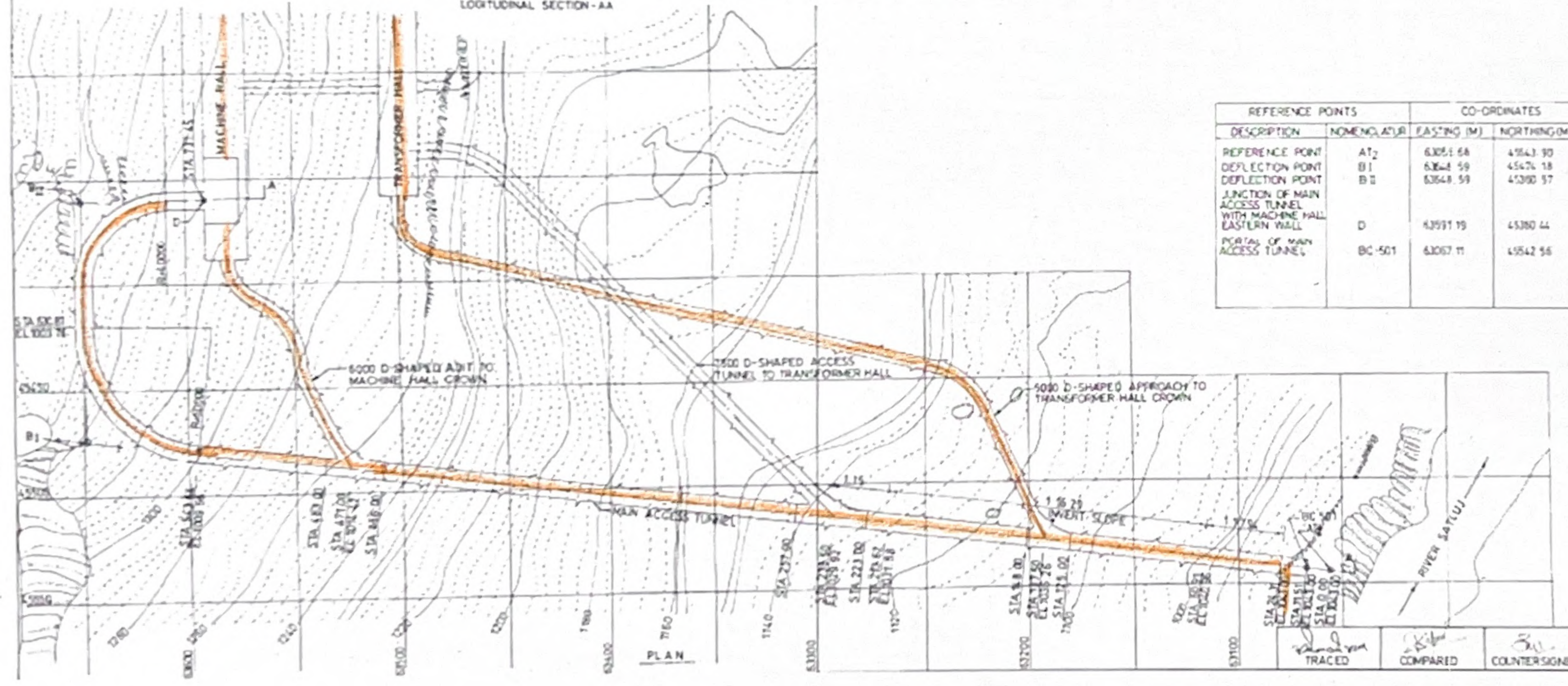

सतलुज जल विद्युत निगम लिमिटेड
 SATLUJ JAL VIDYUT NIGAM LTD
 नथपा भाकरी जल विद्युत परियोजना (हि.प्र.)
 NATHPA JHAKRI H.E. PROJECT (H.P.)
 POWER HOUSE COMPLEX
 MAIN ACCESS TUNNEL
 LAYOUT PLAN AND L-SECTION

DSGN ER M G THAKUR	CHD ER P A KOHLI	RCM ER S C MANJIAN
DRWN SH PRINAN SHARMA	SUBM ER R S CHAUHAN	APPD ER R SINGH

POWER HOUSE (DESIGNS) SHIMLA (H.P.)
 NO. N.J.-PH-11 MARCH, 2005 (DRG NO. N.J.H.P.-DCR-095)

PLAN :- SHOWING PAINTING WORK ON VENTILATION DUCTS IN POWER-HOUSE CMAT, CROWN OF MACHINE HALL AND CROWN OF TRANSFORMER HALL

(Handwritten signature and date)
 30/04/25
 CRIP 90 12/10/08



एसजेवीएन लिमिटेड SJVN Ltd.
(भारत सरकार तथा हिमाचल प्रदेश सरकार का सांझा उपक्रम)
(Navratna CPSE)

(6X250MW नाथपा झाकड़ी जल विद्युत स्टेशन)

प्रापण एवं संविदा विभाग, झाकड़ी, जिला शिमला, हि° प्र°- 172201

फोन. 01782-275236, <http://www.sjvn.nic.in>

जी एस टी संख्या (GST No.) 02AAICS1307F1ZY

सिन् संख्या (CIN No.) L40101HP1988GOI008409

निविदा आमन्त्रण सूचना

एसजेवीएन लि० की ओर से निम्नलिखित कार्य के लिए एतद्वारा एच.पी.पी.डब्ल्यू.डी/सी.पी.डब्ल्यू.डी/एच.पी.एस.ई. बी/सार्वजनिक उपकरणों/किसी सरकारी/अर्ध सरकारी संगठन के साथ सड़क/भवन व अन्य सिविल कार्यों के लिए उपयुक्त सूचीबद्ध पंजीकृत / योग्य ठेकेदारों (**Except JV/ Consortium**) से द्विबोली प्रणाली के अर्न्तगत खुली ई-निविदाएं आमंत्रित की जाती हैं:-

निविदा क्रमांक	कार्य का नाम	अनुमानित लागत रूपए में	निविदा दस्तावेज का मूल्य	बयाना राशि	बोलियों को डाउनलोड करने की अंतिम तिथि एवं समय	बोलियों को अपलोड करने की अंतिम तिथि एवं समय	बोली खुलने की तिथि एवं समय	कार्य पूरा करने की अवधि
पीसीडी 2961	Painting Work on Ventilation Ducts of NJHPS Power House Complex	40,93,072 (without GST)	3540/- (Rs.3,000/- + GST @18% i.e. Rs. 540/-)	81861	03/03/2026 (20:00 Hrs.) से 24/03/2026 (12:00 Hrs)	25/03/2026 (13:00 Hrs)	25/03/2026 (14:00 Hrs)	05 months

टिप्पणी:-

- विस्तृत निविदा आमन्त्रण सूचना, निविदा दस्तावेज, आई.एफ.बी., बीओक्यू अनुसूची-1 (सामान्य सूचना व बैंक खाता विवरण) एवं अनुसूची-2 तथा अनुलग्नक बेबसाइट <https://etender.sjvn.co.in>, www.sjvn.nic.in & www.eprocure.gov.in पर दिनांक 03.03.2026 (20:00 Hrs.) से उपलब्ध है।
- बोलियों को इलैक्ट्रॉनिकली ई-टेंडरिंग के माध्यम से <https://etender.sjvn.co.in> पर जमा किया जाए।
- किसी भी शुद्धि और संशोधन को, यदि कोई हुई तो, उसे <https://etender.sjvn.co.in> एवं उपरोक्त बेबसाइट पर अपलोड कर दिया जाएगा। अतः सभी बोलीदाताओं से अनुरोध है कि बोली जमा करने की निर्धारित तिथि तक 'साइट' को नियमित तौर पर देखते रहें।

हिते एवं कृते एसजेवीएन लि०

विभागाध्यक्ष

प्रापण एवं संविदा विभाग, एनजेएचपीएस,
एसजेवीएन लि०, झाकड़ी-172201

Registered & Corporate Office	SJVN Corporate Head Quarter, Shanan, Shimla, Himachal Pradesh Pin No.-171006	Expediting Office	SJVN Limited, Office Block, Tower-1, 6 th floor, NBCC Complex, East Kidwai Nagar, New Delhi-110023.
-------------------------------	--	-------------------	--



एसजेवीएन लिमिटेड SJVN Ltd.
(भारत सरकार तथा हिमाचल प्रदेश सरकार का सांझा उपक्रम)
(Navratna CPSE)
(6X250MW नाथपा झाकड़ी जल विद्युत स्टेशन)

प्रापण एवं संविदा विभाग, झाकड़ी, जिला शिमला, हि° प्र°- 172201

फोन. 01782-275236, <http://www.sjvn.nic.in>
जी एस टी संख्या (GST No.) 02AAICS1307F1ZY
सिन् संख्या (CIN No.) L40101HP1988GOI008409

NOTICE INVITING TENDERS

Open **e-tenders** under two bid system are hereby invited on behalf of SJVN Limited from appropriate class of registered / eligible contractors (**Except JV/ Consortium**) for road, building and other civil works enlisted with HPPWD / CPWD / HPSEB / Public Undertakings / any other Govt./ Semi Govt. Organization for the following work: -

Tender No.	Name of Work.	Estimated Cost. (In Rs.)	Tender Documents cost (In Rs.)	EMD (In Rs.)	Date of availability / downloading of bid document.	Last date of submission/ uploading of bids.	Date of opening of bid	Completion Time
PCD-2961	Painting Work on Ventilation Ducts of NJHPS Power House Complex	40,93,072 (without GST)	3540/- (Rs.3,000/- + GST @18% i.e. Rs. 540/-)	81861	03/03/2026 (20:00 Hrs.) से 24/03/2026 (12:00 Hrs.)	25/03/2026 (13:00 Hrs)	25/03/2026 (14:00 Hrs)	05 माह

Note :-

- (i) The detailed NIT, Tender document, IFB, BOQ Schedule-1 (General Information & Bank Account Detail) & Schedule-2 and Annexures shall be available at <https://etender.sjvn.co.in>, www.sjvn.nic.in & www.eprocure.gov.in w.e.f 03.03.2026 (20:00 Hrs.)
- (ii) The bids are to be submitted electronically through e-tendering at <https://etender.sjvn.co.in>
- (iii) The corrigendum's and amendments if any shall be uploaded on <https://etender.sjvn.co.in> and above websites; therefore, all bidders requested to frequently visit the web sites till the schedule date of submission of bid.

For and on behalf of SJVN Ltd.

**Head of Dept. (HOD),
Procurement & Contract Deptt.,
NJHPS, SJVN Ltd., Jhakri, Distt. Shimla (HP).**

Registered & Corporate Office	SJVN Corporate Head Quarter, Shanan, Shimla, Himachal Pradesh Pin No.-171006	Expediting Office	SJVN Limited, Office Block, Tower-1, 6 th floor, NBCC Complex, East Kidwai Nagar, New Delhi-110023.
-------------------------------	--	-------------------	--

निबंधन एवं शर्तें:-

1. बोली जमा करना:-

(अ) निविदा में निम्नलिखित रूप से दो भाग निहित हों:-

(क) तकनीकी - वाणिज्यिक बोली:

Part-I – Techno-Commercial Bid comprises of the following:-

1. EMD/Bid Security
2. Cost of tender Document
3. Registration certificate as contractor (**Except JV/ Consortium**) for road, building and other civil works enlisted with HPPWD / CPWD / HPSEB / Public Undertakings / any other Govt./ Semi Govt. Organization.
4. GST No., PAN
5. EPF Code No.
6. Schedule -1 & Schedule- 2
7. Documents as per Qualification requirements as per Clause-5 below
8. Bid security Declaration as per Annexure - B,
9. Undertaking as per Annexure-D along with Annexure-II (Guidelines on Banning of Business Dealings),
10. Undertaking of Self certification regarding Local content as per Annexure-E
11. Undertaking as per Annexure - G
12. Undertaking as per Annexure- H

(I) **The bid documents shall be uploaded electronically and submitted online alongwith scanned copies of all the requisite documents. Some of the documents viz. Bid Security (if in the form of FDR/TDR) , Power of Attorney, etc. are required to be submitted in physical form also.**

(II) **The time limit for submission of documents required in physical form shall be ten (10) days after the deadline for submission of e-bids in respect of following documents:-**

- (i) **Bid Security/EMD (If not received online)**
- (ii) **Power of Attorney (if applicable)**
- (iii) **Any other documents required to be submitted in physical form in addition to above as per the requirement of particular tender.**

(III) **The original documents in physical form submitted after the period as specified above shall not be entertained and such bids shall be treated as late bids. If the original documents in physical forms are found to be at variance than the scanned copies submitted earlier alongwith e-bids, the bids will be treated as non-responsive.**

(ख.) **मूल्य बोली: –**

भाग-II – मूल्य बोली

(ब) उपरोक्त डायनामिक शेड्यूल को ऑनलाइन भरना है। मूल्य बोली मूल्यांकन के लिए केवल डायनामिक अनुसूची में बोलीदाता द्वारा उद्धृत दर पर विचार किया जाएगा ।

2. बोली का खोला जाना:

बोली निम्नलिखित क्रम से खोली जाएगी:-

- I) सर्वप्रथम, भाग-I यथा: तकनीकी-वाणिज्यिक भाग को खोला जाएगा ।
- II) भाग-II यथा मूल्य-बोली केवल उन्हीं फर्मों की खोली जाएगी जिनका भाग-I पर्याप्त रूप से अनुकूल पाया जाएगा । Necessary information will be given to successful bidders through website only.

3. कार्य हेतु निविदा, निविदाओं के खुलने की तिथि से 90 दिन की अवधि के लिए स्वीकृत हेतु खुली रहेगी ।

Registered & Corporate Office	SJVN Corporate Head Quarter, Shanan, Shimla, Himachal Pradesh Pin No.-171006	Expediting Office	SJVN Limited, Office Block, Tower-1, 6 th floor, NBCC Complex, East Kidwai Nagar, New Delhi-110023.
-------------------------------	--	-------------------	--

TERMS AND CONDITIONS :

1. BID SUBMISSION :

(A) The tender shall be comprises of two parts in the following manner :

(b) **Techno-Commercial Bid:**

Part-I – Techno-Commercial Bid comprises of the following:-

1. EMD/Bid Security
2. Cost of tender Document
3. Registration certificate as contractor (**Except JV/ Consortium**) for road, building and other civil works enlisted with HPPWD / CPWD / HPSEB / Public Undertakings / any other Govt./ Semi Govt. Organization
4. GST No., PAN
5. EPF Code No.
6. Schedule -1 & Schedule- 2
7. Documents as per Qualification requirements as per Cluause-5 below
8. Bid security Declaration as per Annexure - B,
9. Undertaking as per Annexure-D along with Annexure-II (Guidelines on Banning of Business Dealings),
10. Undertaking of Self certification regarding Local content as per Annexure-E
11. Undertaking as per Annexure - G
12. Undertaking as per Annexure- H

(I) **The bid documents shall be uploaded electronically and submitted online along with scanned copies of all the requisite documents. Some of the documents viz. Bid Security (if in the form of FDR/TDR), Power of Attorney, etc. are required to be submitted in physical form also.**

(II) **The time limit for submission of documents required in physical form shall be ten (10) days after the deadline for submission of e-bids in respect of following documents:-**

(i) **Bid security/EMD (If not received online)**

(ii) **Power of Attorney (if applicable)**

(iii) **Any other documents required to be submitted in physical form in addition to above as per the requirement of particular tender.**

(III) **The original documents in physical form submitted after the period as specified above shall not be entertained and such bids shall be treated as late bids. If the original documents in physical forms are found to be at variance than the scanned copies submitted earlier alongwith e-bids, the bids will be treated as non-responsive.**

(c) **Price bid :**

Part-II- Price bid

(B) **The above dynamic schedule is to be filled **ONLINE**. The price quoted by the bidder only in the dynamic schedule shall be considered for price bid evaluation.**

2. BID OPENING :-

The bid shall be opened in the following sequence:

(i) First of all, the Part-I i.e. Techno-commercial part shall be opened.

(ii) The Part-II i.e. Price bid shall be opened of only those firms whose Part-I of bid found techno-commercially responsive. Necessary information will be given to successful bidders through website only.

3. **Tender for works shall remain open for acceptance for the period of ninety (90) days from the date of opening of tenders.**

Registered & Corporate Office	SJVN Corporate Head Quarter, Shanan, Shimla, Himachal Pradesh Pin No.-171006	Expediting Office	SJVN Limited, Office Block, Tower-1, 6 th floor, NBCC Complex, East Kidwai Nagar, New Delhi-110023.
-------------------------------	--	-------------------	--

4. **बोली दस्तावेज़ और बयाना राशि जमा (ईएमडी/बोली सुरक्षा) की लागत**
- 4.1 **बोली दस्तावेज़ की खरीद की लागत है Rs. 3540- (Rupees Three thousand five hundred forty only) (नॉन रिफंडेबल) i.e.(Rs. 3,000/-+GST @18% i.e. Rs.540/-).**
- 4.2 **ईएमडी/बोली सुरक्षा:** बोली लगाने वाले को बोली के हिस्से के रूप में एक बोली सुरक्षा/बयाना राशि जमा करनी होगी। **Rs. 81,861/- (Rupees Eighty One Thousand Eight Hundred Sixty One only).** यह ईएमडी/बोली सुरक्षा ऑनलाइन या एफडीआर/टीडीआर के माध्यम से जमा की जानी है जैसा कि नीचे 4.4 में बताया गया है।
- 4.3 **The "Cost of Bid document" & "Earnest Money Deposit (EMD)" shall be submitted / deposited through online payment gateway on SRM Portal/e-tendering portal.**

Caution: In the event of funds remitted to wrong beneficiary account number, **SJVN Limited** or its Bank or its service provider would not responsible for the same.

- 4.4 **FDR/TDR:** Please note that EMD (Earnest Money Deposit)/ Bid Security in the form of **FDR/TDR (Pledged in favour of the NJHPS, SJVN Limited)** is also acceptable. The EMD (Earnest Money Deposit)/ Bid Security in the form of **FDR/TDR** shall have to be submitted by the deadline of submission of physical documents indicated above at Sr. No. 1 (A) (a) (I, II & III) in a sealed envelope through post / courier or by hand on the address of HOD (P&C), NJHPS, SJVN Ltd., Jhakri, Tehsil Rampur Bsr., Distt. Shimla (HP)-172201, failing which the bid shall be considered as non-responsive & financial bid will not be opened.

Remarks:- The EMD submitted in the form of BG, DDs, local Cheque/ outstations Cheque will not be considered.

- 4.5 Bid security shall remain valid for a period of 45 days beyond the original bid validity period and beyond any extension subsequently requested. Any correction, alteration and addition in computer generated / other hand written instrument subsequently needs to attested by the appropriate authority of bank.
- 4.6 **Being civil work tender MSEs/NSIC/Startup India registered firms are not exempted from the submission of Cost of Tender Document & Earnest Money Deposit/Bid Security.**
- 4.7 EMD of the bidder shall be forfeited/necessary action may be taken as per bid security declaration, if the bidder withdraws or amends its bids or impairs or derogates from the bid in any respect with in the period of validity of the bid. ***The EMD of the successful bidder shall be retained as contract security until such period the contractor furnishes the required security deposit and shall be released within 30 days from the receipt of the performance security & verification/confirmation thereof.*** If the contractor is failed to fulfill his obligations, the EMD, retained as contract security shall be forfeited/necessary action may be taken as per bid security declaration submitted by the firm along with their bid.
- 4.8 The bid securities/EMD of unsuccessful bidders shall be returned within thirty (30) days after the declaration of result of 1st stage i.e technical evaluation.
- 4.9 **EMD of bidder(s) will be refunded only to designated account submitted by the bidder at the time of registration with SJVN irrespective of mode of payments made.**
- 4.10 **No interest shall be payable by the SJVN on EMD.**
- 4.11 **Tender without cost of document & Bid security/EMD will be rejected.**

Registered & Corporate Office	SJVN Corporate Head Quarter, Shanan, Shimla, Himachal Pradesh Pin No.-171006	Expediting Office	SJVN Limited, Office Block, Tower-1, 6 th floor, NBCC Complex, East Kidwai Nagar, New Delhi-110023.
-------------------------------	--	-------------------	--

4 Cost of Bid Document and Earnest Money deposit (EMD/ Bid Security)

- 4.1 The cost for purchase of bid document is **Rs. 3540- (Rupees Three thousand five hundred forty only) (Non-refundable) i.e. (Rs. 3,000/-+GST @18% i.e. Rs. 540/-)**.
- 4.2 **EMD/Bid Security:** The bidder shall furnish, a bid security/ earnest money as part of the bid amounting to **Rs. 81,861/- (Rupees Eighty One Thousand Eight Hundred Sixty One only)**. This EMD/Bid security is to be submitted through online or FDR/TDR as mentioned at 4.4 below.
- 4.3 The "Cost of Bid document" & "Earnest Money Deposit (EMD)" shall be submitted / deposited through online payment gateway on SRM Portal/e-tendering portal.
Caution: In the event of funds remitted to wrong beneficiary account number, **SJVN Limited** or its Bank or its service provider would not responsible for the same.
- 4.4 **FDR/TDR:** Please note that EMD (Earnest Money Deposit)/ Bid Security in the form of **FDR/TDR (Pledged in favour of the NJHPS, SJVN Limited)** is also acceptable. The EMD (Earnest Money Deposit)/ Bid Security in the form of **FDR/TDR** shall have to be submitted by the deadline of submission of physical documents indicated above at Sr. No. 1 (A) (a) (I, II & III) in a sealed envelope through post / courier or by hand on the address of Dy. General Manager (P&C), NJHPS, SJVN Ltd., Jhakri, Tehsil Rampur Bsr., Distt. Shimla (HP)-172201, failing which the bid shall be considered as non-responsive & financial bid will not be opened.
- Remarks:- The EMD submitted in the form of BG, DDs, local Cheque/ outstations Cheque will not be considered.**
- 4.5 Bid security shall remain valid for a period of 45 days beyond the original bid validity period and beyond any extension subsequently requested. Any correction, alteration and addition in computer generated / other hand written instrument subsequently needs to attested by the appropriate authority of bank.
- 4.6 **Being Civil work tender MSEs/NSIC/Startup India registered firms are not exempted from the submission of Cost of Tender Document & Earnest Money Deposit/Bid Security.**
- 4.7 EMD of the bidder shall be forfeited/necessary action may be taken as per bid security declaration, if the bidder withdraws or amends its bids or impairs or derogates from the bid in any respect with in the period of validity of the bid. ***The EMD of the successful bidder shall be retained as contract security until such period the contractor furnishes the required security deposit and shall be released within 30 days from the receipt of the performance security & verification/confirmation thereof.*** If the contractor is failed to fulfill his obligations, the EMD, retained as contract security shall be forfeited/necessary action may be taken as per bid security declaration submitted by the firm along with their bid.
- 4.8 The bid securities/EMD of unsuccessful bidders shall be returned within thirty (30) days after the declaration of result of 1st stage i.e technical evaluation.
- 4.9 **EMD of bidder(s) will be refunded only to designated account submitted by the bidder at the time of registration with SJVN irrespective of mode of payments made.**
- 4.10 **No interest shall be payable by the SJVN on EMD.**
- 4.11 **Tender without cost of document & Bid security/EMD will be rejected.**

Registered & Corporate Office	SJVN Corporate Head Quarter, Shanan, Shimla, Himachal Pradesh Pin No.-171006	Expediting Office	SJVN Limited, Office Block, Tower-1, 6 th floor, NBCC Complex, East Kidwai Nagar, New Delhi-110023.
-------------------------------	--	-------------------	--

5. अपेक्षित योग्यताएं:

बोलीदाता द्वारा बोलियों को जमा करने से पूर्व यह सुनिश्चित करना उनके स्वयं के हित में होगा कि वे निम्नलिखितानुसार अपेक्षित योग्यताओं को पूरा करता हो और इन सभी की प्रतियों को तकनीकी-वाणिज्यिक बोली के साथ संलग्न (upload) कर प्रेषित करें:-

SJVN Limited has to finalize its tender within a limited time schedule. Therefore it may not be feasible in all case for SJVN Limited to seek clarifications in respect of incomplete offers. The decision will be made based on available documents. Prospective bidders are advised to ensure that their bids are complete in all respects and confirm to our terms and conditions. Bids not complying with SJVN Limited requirements may be rejected without seeking any clarifications.

क. अपनी तकनीकी-वाणिज्यिक बोली के साथ इच्छुक निविदाकरों को उनका पंजीकरण/लाइसेंस, जी एस टी स0, पैन, ई.पी.एफ. कोड नं0 इत्यादि आवश्यक रूप में जमा करना (upload) चाहिए।

ख. निविदा हेतु पात्रता उन्हीं फर्म/ठेकेदारों तक सीमित होगी जो निम्नलिखित शर्तों को पूरा करेंगे और दस्तावेजी प्रमाण जमा करेंगे:-

(i) **वित्तीय टर्न-ओवर:** 31 मार्च 2025 को समाप्त हुए वित्तीय वर्ष, से गत 3 वर्षों की अवधि के दौरान बोलीदाता का औसत वार्षिक वित्तीय टर्न-ओवर कम से कम **Rs. 12,27,922/- (Rs. Twelve Lakh Twenty Seven Thousand Nine Hundred Twenty Two only)** होना चाहिए।

Remarks: Annual financial turnover should be supported by Annual Report (Balance Sheet and Profit & Loss Statement) of last 3 (three) years ending 31/03/2025. In case the financial turnover of previous financial year 2024-25 is not finalized till the submission of bid, the provisional financial turnover for the year ending 31/03/2025 should be submitted by the bidder duly authenticated/audited by the concerned statutory auditor or an authorized practicing Chartered Accountant or an authorized firm of Chartered Accountants.

(ii) **कार्य अनुभव:** समान प्रकार के कार्यों को सफलतापूर्वक पूर्ण करने का अनुभव जो कि पिछले 07 वर्ष की अवधि में पूरे किए गए हों। इन सात वर्ष की अवधि में किए गए कार्यों का अनुभव जो कि निविदा आमंत्रित करने वाले माह से पिछले माह की अंतिम तिथि पहले का हो, निम्न प्रकार होना चाहिए:-

(a) समान प्रकार के पूर्ण किए गए तीन कार्य जिनकी लागत **₹ 16,37,229/- (Rupees Sixteen Lakh Thirty Seven Thousand Two Hundred Twenty Nine only)** से कम न हो।

अथवा

(b). समान प्रकार के पूर्ण किए गए दो कार्य जिनकी लागत **₹ 20,46,536/- (Rupees Twenty Lakh Forty Six Thousand Five Hundred Thirty Six only)** से कम न हो।

अथवा

(c). समान प्रकार के पूर्ण किए गए एक कार्य जिनकी लागत **₹ 32,74,458/- (Rupees Thirty Two Lakh Seventy Four Thousand Four Hundred Fifty Eight only)** से कम न हो।

***Remarks: - The above-mentioned values are exclusive of taxes.**

टिप्पणी:-*(i) समान कार्य से तात्पर्य है:-“ Civil work which involves the execution of most of the items related to the B.O.Q. of this work and/or civil work of higher specification”* से संबंधित कार्य।

ii) In the support of similar work experience, the bidder must have to submit/upload documentary proof of the work experience along with copies of the B.O.Q. of the executed work. In case documentary proof of work experience is issued by private company (ies) /firm (s), then copy (ies) of TDS for the same work are also needs to be submitted by the bidder.

iii) Further any short full documents i.e LOA/BOQ/Completion certificate/TDS etc. for the already submitted “work experience” along with bid can be sought. However, NO new work experience/LOA/ Contract shall be asked during the evaluation of bids.

ग. ऊपर वर्णित आवश्यकताएं न्यूनतम हैं और एसजेवीएन लि0 किसी भी अतिरिक्त सूचना को मांगने का अधिकार सुरक्षित रखती है।

Registered & Corporate Office	SJVN Corporate Head Quarter, Shanan, Shimla, Himachal Pradesh Pin No.-171006	Expediting Office	SJVN Limited, Office Block, Tower-1, 6 th floor, NBCC Complex, East Kidwai Nagar, New Delhi-110023.
-------------------------------	--	-------------------	--

5. **Qualification requirements:**

Before the submission of bids the bidder in his own interest ensures that he meets the requisite qualification criteria as given below and shall upload copies of the same along with the techno-commercial bid: -

SJVN Limited has to finalize its tender within a limited time schedule. Therefore it may not be feasible in all case for SJVN Limited to seek clarifications in respect of incomplete offers. The decision will be made based on available documents. Prospective bidders are advised to ensure that their bids are complete in all respects and confirm to our terms and conditions. Bids not complying with SJVN Limited requirements may be rejected without seeking any clarifications.

(A). The intending Tenderer must have their registration / license, PAN, GST No., EPF Code No. etc. and upload along with their Techno- commercial bid.

(B) Eligibility for the tender shall be restricted to those parties / contractors who will fulfill the following conditions and upload documentary proof:-

(i) **Financial Turnover:** The Average Annual Financial turnover of the bidder during the last three (03) years, ending 31st March 2025 should be at least **Rs. 12,27,922/- (Rs. Twelve Lakh Twenty Seven Thousand Nine Hundred Twenty Two only)**

Remarks: Annual financial turnover should be supported by Annual Report (Balance Sheet and Profit & Loss Statement) of last 3 (three) years ending 31/03/2025. In case the financial turnover of previous financial year 2024-25 is not finalized till the submission of bid, the provisional financial turnover for the year ending 31/03/2025 should be submitted by the bidder duly authenticated/audited by the concerned statutory auditor or an authorized practicing Chartered Accountant or an authorized firm of Chartered Accountants.

(ii) **Work Experience:** The bidder should have an experience of having successfully completed similar works/contracts as any of the following criteria during last seven (07) years ending last day of month previous to one in which applications are invited should be either of the following:

(a) Three similar completed works costing not less than **₹ 16,37,229/- (Rupees Sixteen Lakh Thirty Seven Thousand Two Hundred Twenty Nine only)** each.

OR

(b) Two similar completed works costing not less than **₹ 20,46,536/- (Rupees Twenty Lakh Forty Six Thousand Five Hundred Thirty Six only)** each.

OR

(c) One similar completed work costing not less than **₹ 32,74,458/- (Rupees Thirty Two Lakh Seventy Four Thousand Four Hundred Fifty Eight only)** .

***Remarks: - The above-mentioned values are exclusive of taxes.**

Note:-

(i) **Similar Works means works related to:-** “Civil work which involves the execution of most of the items related to the B.O.Q. of this work and/or civil work of higher specification.”

(ii) **In the support of similar work experience, the bidder must have to submit/upload documentary proof of the work experience along with copies of the B.O.Q. of the executed work. In case documentary proof of work experience is issued by private company (ies) /firm (s), then copy (ies) of TDS for the same work are also needs to be submitted by the bidder.**

(iii) **Further any short full documents i.e LOA/BOQ/Completion certificate/TDS etc. for the already submitted “work experience” along with bid can be sought. However, NO new work experience/LOA/ Contract shall be asked during the evaluation of bids.**

(C) The above mentioned requirements are minimum and the **SJVN Limited**, reserves the right to ask for any additional information.

Registered & Corporate Office	SJVN Corporate Head Quarter, Shanan, Shimla, Himachal Pradesh Pin No.-171006	Expediting Office	SJVN Limited, Office Block, Tower-1, 6 th floor, NBCC Complex, East Kidwai Nagar, New Delhi-110023.
-------------------------------	--	-------------------	--

Remarks:- Being Civil work MSEs/NSIC/Startup India registered firms are not relaxed from the condition of Prior Financial turnover and prior work done experience . MSE's/NSIC/Startup India registered firms have to submit/upload financial turnover and work done experience certificate of similar work fulfill independently as per Qualifying criteria of tender

- 6 ऊपर वर्णित प्रावधानों के होते हुए भी, यदि एसजेवीएन के समग्र हित में परिस्थितिवश आवश्यक हुआ तो बोलीदाता की कार्य क्षमता और कार्य के निष्पादन की क्षमता को मूल्यांकित करने का अधिकार एसजेवीएन के अपने पास सुरक्षित रखता है ।
7. कार्य की वस्तु अनुमानित दर के साथ मात्रा के बिल में दी गई है! बोली लगाने वाले को पूरे कार्य के लिए अपनी दरें और कीमतें %आयु (अर्थात दो (02) दशमलव स्थानों तक) में पेश करनी होंगी, जिसमें सामग्री, श्रम, उपकरण, कर शामिल होंगे। जीएसटी अधिनियम के अनुसार जीएसटी चालान जमा करने पर लागू जीएसटी अलग से जारी किया जाएगा।

8. भुगतान प्रक्रिया :

If the payment due to the Contractor for any undisputed amount for which interim bill has been approved by the Engineer – in – Charge, is delayed by more than **15 days** from the due date of payment (i.e. **45 days** from date of submission of bill) an interest @ of 8% per annum and acceptance thereof by Engineer in Charge, shall be payable to the Contractor for the actual number of days of delay in payment of bill beyond the above said period of **15 days**.

in case of Micro & Small Enterprise (MSE) following provision shall apply :

All the payments for the supplies and/or services (as applicable) rendered by MSEs (Micro & Small Enterprises) supplier/Contractor under the contract shall be released within forty five (45) days from the day of acceptance, subject to submission of invoice on or before the day of acceptance.

Day of acceptance means day of actual delivery of Plant or the rendering of services; or where any objection is made in writing by SJVN regarding acceptance of Plant or service within fifteen days from the date of delivery of Plant or the rendering of services, the day on which such objection is removed by the contractor/supplier.

In case payments are not released as mentioned above, SJVN shall pay the principal amount plus compound interest with monthly rests from the date immediately following the date agreed upon @ three times of bank rates as notified by Reserve Bank of India from time to time.

- 09 सफल बोलीदाता कार्य को प्रारम्भ करने से पूर्व प्रभारी अभियंता के कार्यालय में श्रम कानून के अनुसार वैध श्रम लाइसेंस की सत्यापित प्रति अवश्य जमा कराएं ।
- 10 कार्य उस L-1 बोलीदाता को अवार्ड किया जाएगा जिसकी बोली समग्र रूप से तत्त्वतः (substantially) अनुकूल पायी जाएगी । The tender has been invited on one %age figure (i.e. at par/ above / below basis). Bidder has to quote the %age unit rate in figure upto 2 decimal places and same shall be applicable uniformly on all items of Annexure-A. For example, if a bidder has quoted 5 %, the same shall be considered as 5.00%.

Registered & Corporate Office	SJVN Corporate Head Quarter, Shanan, Shimla, Himachal Pradesh Pin No.-171006	Expediting Office	SJVN Limited, Office Block, Tower-1, 6 th floor, NBCC Complex, East Kidwai Nagar, New Delhi-110023.
-------------------------------	--	-------------------	--

Remarks:- Being Civil work MSEs/NSIC/Startup India registered firms are not relaxed from the condition of Prior Financial turnover and prior work done experience . MSE's/NSIC/Startup India registered firms have to submit/upload financial turnover and work done experience certificate of similar work fulfill independently as per Qualifying criteria of tender.

6. Not with standing anything stated above, the **SJVN Limited** reserves the right to assess bidder's capability and capacity to perform the works, should the circumstances warrant such an assessment in the overall interest of the **SJVN Limited**.
7. The item of work is given in the Bill of Quantities along with estimated rate & amount of the Bidding Documents. The Bidder shall be required to offer their rates and prices in %age (i.e. upto two (02) decimal places) for the whole work, which shall include material, labour, equipment, taxes & duties etc. except **GST**.
The applicable GST shall be released separately on submission of GST invoice as per GST act.
8. **Payment Procedure:**

If the payment due to the Contractor for any undisputed amount for which interim bill has been approved by the Engineer – in – Charge, is delayed by more than **15 days** from the due date of payment (i.e. **45 days** from date of submission of bill) an interest @ of 8% per annum and acceptance thereof by Engineer in Charge, shall be payable to the Contractor for the actual number of days of delay in payment of bill beyond the above said period of **15 days**.

in case of Micro & Small Enterprise (MSE) following provision shall apply :

All the payments for the supplies and/or services (as applicable) rendered by MSEs (Micro & Small Enterprises) supplier/Contractor under the contract shall be released within forty five (45) days from the day of acceptance, subject to submission of invoice on or before the day of acceptance.

Day of acceptance means day of actual delivery of Plant or the rendering of services; or where any objection is made in writing by SJVN regarding acceptance of Plant or service within fifteen days from the date of delivery of Plant or the rendering of services, the day on which such objection is removed by the contractor/supplier.

In case payments are not released as mentioned above, SJVN shall pay the principal amount plus compound interest with monthly rests from the date immediately following the date agreed upon @ three times of bank rates as notified by Reserve Bank of India from time to time.

- 09 The successful bidder must submit the attested copy of valid labour license in the O/o Engineer Incharge before start of work at site.
- 10 The work will be awarded to L-1 bidder whose bid will be found substantially responsive on overall basis. The tender has been invited on one %age figure (i.e. at par/ above / below basis). Bidder has to quote the %age unit rate in figure upto 2 decimal places and same shall be applicable uniformly on all items of Annexure-A. For example, if a bidder has quoted 5 %, the same shall be considered as 5.00%.

Registered & Corporate Office	SJVN Corporate Head Quarter, Shanan, Shimla, Himachal Pradesh Pin No.-171006	Expediting Office	SJVN Limited, Office Block, Tower-1, 6 th floor, NBCC Complex, East Kidwai Nagar, New Delhi-110023.
-------------------------------	--	-------------------	--

11. त्रुटियों का सुधार (संभव सीमा तक लागू)।

The prices are to be filled in ONLINE DYNAMIC Schedules as under:-

- A. The bidder has to fill the Unit Rates in %age only after selecting at par/above/below option up to 2 decimal places.
- B. The entered %age in figures shall be automatically converted in to total amount.

12. भ्रष्ट या कपटपूर्ण आचरण

It is expected from the bidders/Contractor and/or any of its personnel, or its agents, or its Sub-contractors, manufacturer, sub-consultants, services providers, suppliers and/or their employees that they will observe the high standard of ethics during the bidding process and execution of such Contracts. In pursuance to this policy:

a) For the purpose of this provision, the terms set-forth below shall mean as under:

- i) "Corrupt practice" means the offering, giving, receiving or soliciting of anything of value to influence the action of a public official in the procurement process or in Contract execution.
- ii) "fraudulent practice" means a misrepresentation or omission of facts in order to influence a procurement process or the execution of a contract to be detriment of the Employer, and includes collusive practice among Applicants (prior to or after bid submission) designed to establish bid prices at artificial non-competitive levels and to deprive the Employer of the benefits of free and open competition.

b) A Bid shall be rejected by the Employer if it is determined at any stage that respective bidders / Contractor and/or any of its personnel, or its agents, or its Sub-contractors, manufacturer, sub-consultants, services providers, suppliers and/or their employees has engaged in corrupt or fraudulent or collusive practices in competing for the Contract in question.

c) The Employer will declare a bidder/contractor ineligible or may terminate the contract, either indefinitely or for a stated period of time, to be awarded a Contract if it at any time determines that the bidders/Contractor and/or any of its personnel, or its agents or its Sub-contractors, manufacturer, sub-consultants, services providers, suppliers and/or their employees has engaged In corrupt or fraudulent or collusive practices In competing for or in executing the Contract In question.

d) All the bidders/service providers/vendors /consultants etc shall be requested to furnish a certificate regarding presentation and detection of fraud as per Annexure-D along with Annexure II (Guidelines on Banning of Business Dealings).

Registered & Corporate Office	SJVN Corporate Head Quarter, Shanan, Shimla, Himachal Pradesh Pin No.-171006	Expediting Office	SJVN Limited, Office Block, Tower-1, 6 th floor, NBCC Complex, East Kidwai Nagar, New Delhi-110023.
-------------------------------	--	-------------------	--

11. **Correction of Errors (Applicable to extent possible).**

The prices are to be filled in ONLINE DYNAMIC Schedules as under:-

- A. The bidder has to fill the Unit Rates in %age only after selecting at par/above/below option up to 2 decimal places.**
- B. The entered %age in figures shall be automatically converted in to total amount.**

12. **Corrupt or Fraudulent Practices**

It is expected from the bidders/Contractor and/or any of its personnel, or its agents, or its Sub-contractors, manufacturer, sub-consultants, services providers, suppliers and/or their employees that they will observe the high standard of ethics during the bidding process and execution of such Contracts. In pursuance to this policy:

a) For the purpose of this provision, the terms set-forth below shall mean as under:

i) "Corrupt practice" means the offering, giving, receiving or soliciting of anything of value to influence the action of a public official in the procurement process or in Contract execution.

ii) "fraudulent practice" means a misrepresentation or omission of facts in order to influence a procurement process or the execution of a contract to be detriment of the Employer, and includes collusive practice among Applicants (prior to or after bid submission) designed to establish bid prices at artificial non-competitive levels and to deprive the Employer of the benefits of free and open competition.

b) A Bid shall be rejected by the Employer if it is determined at any stage that respective bidders / Contractor and/or any of its personnel, or its agents, or its Sub-contractors, manufacturer, sub-consultants, services providers, suppliers and/or their employees has engaged in corrupt or fraudulent or collusive practices in competing for the Contract in question.

c) The Employer will declare a bidder/contractor ineligible or may terminate the contract, either indefinitely or for a stated period of time, to be awarded a Contract if it at any time determines that the bidders/Contractor and/or any of its personnel, or its agents or its Sub-contractors, manufacturer, sub-consultants, services providers, suppliers and/or their employees has engaged In corrupt or fraudulent or collusive practices In competing for or in executing the Contract In question.

d) All the bidders/service providers/vendors /consultants etc shall be requested to furnish a certificate regarding presentation and detection of fraud as per Annexure-D along with Annexure II (Guidelines on Banning of Business Dealings).

Registered & Corporate Office	SJVN Corporate Head Quarter, Shanan, Shimla, Himachal Pradesh Pin No.-171006	Expediting Office	SJVN Limited, Office Block, Tower-1, 6 th floor, NBCC Complex, East Kidwai Nagar, New Delhi-110023.
-------------------------------	--	-------------------	--

13. सार्वजनिक खरीद (मेक इन इंडिया को प्राथमिकता), 2017 के तहत स्थानीय आपूर्तिकर्ताओं से वस्तुओं/सेवाओं/कार्यों की खरीद और संशोधित पीपीपी एमआईआई आदेश, दिनांक 16-09-2020 और एमओपी आदेश दिनांक 20-12-2018 & 28-07-2020.

DPIIT issued PP (PMI) Order 2017 for encouraging Make in India and promoting domestic manufacturing. Pursuant to DPIIT orders, MOP notified in December, 2018 Purchase Preference (Linked with local content) for Thermal, Hydro and Transmission Sub-sectors and for distribution sector vide order dated 17.03.2020. DPIIT issued a revised PPP MII order, dated 16-09-2020 and MOP orders dated 20-12-2018 & 28-07-2020.

Local Content:- ‘Local Content’ means the amount of value added in India which shall, unless otherwise prescribed by the Nodal Ministry, be the total value of the item procured (excluding net domestic indirect taxes) minus the value of imported content in the item (including all custom duties) as a proportion of the total value, in percent.

Class-I local supplier:- ‘Class-I local supplier’ means a supplier or service provider, whose goods, services or works offered for procurement , has minimum 50% local content, as defined in DPIIT order dated 16-09-2020.

- (i) *In line with the DPIIT PPP-MII order dated 16.09.2020 and MOP orders dated 20.12.2018 & 28.07.2020, “Only Class-I Local Supplier” shall be eligible to bid in this tender and the bidder shall upload the Self-Certification as per Annexure-E, certifying that the item offered meets the Local Content requirement for Class-I Local Supplier, on letter head of the Firm.*
- (ii) “Self-declarations/ auditor’s/ accountant’s certificates submitted by the manufacturer/ supplier may be verified randomly by the committee constituted as per MOP Order 28-07-2020. In case of false documents/misrepresentation of the facts requisite action against such manufacturer/ supplier will be taken based on the recommendation of the Committee”.

Registered & Corporate Office	SJVN Corporate Head Quarter, Shanan, Shimla, Himachal Pradesh Pin No.-171006	Expediting Office	SJVN Limited, Office Block, Tower-1, 6 th floor, NBCC Complex, East Kidwai Nagar, New Delhi-110023.
-------------------------------	--	-------------------	--

13. Procurement of Goods/Services/Works from Local Suppliers under Public Procurement (Preference to Make in India), 2017 and revised PPP MII order, dated 16-09-2020 and MOP orders dated 20-12-2018 & 28-07-2020.

DPIIT issued PP (PMI) Order 2017 for encouraging Make in India and promoting domestic manufacturing. Pursuant to DPIIT orders, MOP notified in December, 2018 Purchase Preference (Linked with local content) for Thermal, Hydro and Transmission Sub-sectors and for distribution sector vide order dated 17.03.2020. DPIIT issued a revised PPP MII order, dated 16-09-2020 and MOP orders dated 20-12-2018 & 28-07-2020.

Local Content:- ‘Local Content’ means the amount of value added in India which shall, unless otherwise prescribed by the Nodal Ministry, be the total value of the item procured (excluding net domestic indirect taxes) minus the value of imported content in the item (including all custom duties) as a proportion of the total value, in percent.

Class-I local supplier:- ‘Class-I local supplier’ means a supplier or service provider, whose goods, services or works offered for procurement , has minimum 50% local content, as defined in DPIIT order dated 16-09-2020.

- (i) *In line with the DPIIT PPP-MII order dated 16.09.2020 and MOP orders dated 20.12.2018 & 28.07.2020, “Only Class-I Local Supplier” shall be eligible to bid in this tender and the bidder shall upload the Self-Certification as per Annexure-E, certifying that the item offered meets the Local Content requirement for Class-I Local Supplier, on letter head of the Firm.*
- (ii) “Self-declarations/ auditor’s/ accountant’s certificates submitted by the manufacturer/ supplier may be verified randomly by the committee constituted as per MOP Order 28-07-2020. In case of false documents/misrepresentation of the facts requisite action against such manufacturer/ supplier will be taken based on the recommendation of the Committee”.

Registered & Corporate Office	SJVN Corporate Head Quarter, Shanan, Shimla, Himachal Pradesh Pin No.-171006	Expediting Office	SJVN Limited, Office Block, Tower-1, 6 th floor, NBCC Complex, East Kidwai Nagar, New Delhi-110023.
-------------------------------	--	-------------------	--

- 14 **बिल ट्रैकिंग सिस्टम** : Prior to the submission of the bills in physical form, supplier shall submit the bills in SJVN vendor bill tracking portal available in SJVN official website <https://www.sjvn.nic.in> under quick link section. Further, supplier may track the status of bills online through Vendor Bill tracking system. In order to use this system, a user manual for supplier is available under Vendor bill tracking system section. Supplier is required to enter the user ID, password and OTP (one time password) for every log in. The user ID and password shall be obtained from the concerned department of SJVN Ltd. However, the OTP will be received to the supplier in the registered mobile number provided by supplier to the concerned department. Once the supplier has received its username and password from the concerned department, supplier shall follow the below mentioned steps:
- (i) Once supplier received the user ID and password from the concerned department, the supplier can log in to vendor bill tracking system with user ID, password and OTP.
 - (ii) After log in, supplier shall enter the details required in the vendor portal screen and submit the invoice specifically to the concerned SJVN official's email ID (abcd@sjvn.nic.in), after submission a unique VITMS number (Reference Number) will be generated and supplier will receive an automated unique VITMS number (Reference Number) both in its automated unique email ID and mobile number.
 - (iii) On receipt of the physical bill, concerned SJVN official shall online acknowledge the receipt of the bill. All the actions taken by the concerned officials of SJVN can be easily been tracked in the "Invoice Status Section" by supplier.
 - (iv) After the final payment, vendor can download the details of the payment under check forwarding details section on the invoice upload and track screen
- 15 सशर्त/टेलिग्राफिक निविदाएं या धरोहर राशि या निविदा-दस्तावेज लागत राशि रहित निविदाओं पर विचार नहीं किया जाएगा ।
- 16 यदि निविदाओं को खुलने या प्राप्त करने के दिन सार्वजनिक अवकाश अथवा अस्पष्ट इंटरनेट सम्पर्क हो तो ऐसी स्थिति में निविदा अगले कार्य-दिवस को उसी समय खोली जाएगी ।
- 17 किसी भी या सभी निविदाओं को बिना कोई कारण बताएं स्वीकार या रद्द करने का अधिकार एसजेवीएन के पास सुरक्षित है ।
- 18 SJVN Limited reserves the right to cancel/withdraw the invitation for bid without assigning any reason and shall bear no liability whatsoever consequent upon such a decision
- 19 यदि हिन्दी व अंग्रेजी भाषा के प्रावधानों में किसी प्रकार का विरोधाभास परिलक्षित होता है तब अंग्रेजी भाषा के प्रावधानों को ही मान्य माना जाएगा ।

Registered & Corporate Office	SJVN Corporate Head Quarter, Shanan, Shimla, Himachal Pradesh Pin No.-171006	Expediting Office	SJVN Limited, Office Block, Tower-1, 6 th floor, NBCC Complex, East Kidwai Nagar, New Delhi-110023.
-------------------------------	--	-------------------	--

14 Bill Tracking System: Prior to the submission of the bills in physical form, supplier shall submit the bills in SJVN vendor bill tracking portal available in SJVN official website <https://www.sjvn.nic.in> under quick link section. Further, supplier may track the status of bills online through Vendor Bill tracking system. In order to use this system, a user manual for supplier is available under Vendor bill tracking system section. Supplier is required to enter the user ID, password and OTP (one time password) for every log in. The user ID and password shall be obtained from the concerned department of SJVN Ltd. However, the OTP will be received to the supplier in the registered mobile number provided by supplier to the concerned department. Once the supplier has received its username and password from the concerned department, supplier shall follow the below mentioned steps:

- (i) Once supplier received the user ID and password from the concerned department, the supplier can log in to vendor bill tracking system with user ID, password and OTP.
 - (ii) After log in, supplier shall enter the details required in the vendor portal screen and submit the invoice specifically to the concerned SJVN official's email ID (abcd@sjvn.nic.in), after submission a unique VITMS number (Reference Number) will be generated and supplier will receive an automated unique VITMS number (Reference Number) both in its automated unique email ID and mobile number.
 - (iii) On receipt of the physical bill, concerned SJVN official shall online acknowledge the receipt of the bill. All the actions taken by the concerned officials of SJVN can be easily been tracked in the "Invoice Status Section" by supplier.
 - (iv) After the final payment, vendor can download the details of the payment under check forwarding details section on the invoice upload and track screen.
15. The bids in physical form /Conditional / telegraphic tenders or tenders without earnest money shall not be considered.
16. If it happens to be holiday or poor internet connectivity on the date of receipt / opening of the tenders, the same shall be opened on the next working day at the same time.
17. SJVN Ltd. reserves the right to accept or reject any or all tenders without assigning any reasons thereof.
18. SJVN Limited reserves the right to cancel/withdraw the invitation for bid without assigning any reason and shall bear no liability whatsoever consequent upon such a decision
19. In case of any contradiction between Hindi & English version of NIT, the provision of English version of NIT will prevails.

Registered & Corporate Office	SJVN Corporate Head Quarter, Shanan, Shimla, Himachal Pradesh Pin No.-171006	Expediting Office	SJVN Limited, Office Block, Tower-1, 6 th floor, NBCC Complex, East Kidwai Nagar, New Delhi-110023.
-------------------------------	--	-------------------	--

20. अनुबंध समझौते पर हस्ताक्षर.

- ▶ **The contract agreement shall be signed at NJHPS, SJVN, Jhakri (INDIA) in the office of undersigned within 15 days from the date of issue of LOA.**
- ▶ The Contract Agreement (s) will be signed in two (02) originals on non – judicial Stamp Paper (02 Nos) of ₹ 100/- each along with two (02Nos) copies of judicial paper of ₹ 1/-each within fifteen (15) days from the issue of Notification of awards/letter of Awards ***The non-judicial stamp papers & judicial papers are to be purchased from Himachal Pradesh only.***
- ▶ The agreement shall be signed by the authorized signatory of service provider/contractor , **While signing of agreement, satisfactory evidence of authority of the Authorized Signatory signing on behalf of the service provider shall be furnished on non-judicial stamp paper of an appropriate value in the form of a Power of Attorney/Authorization Letter, duly notarized by a Notary Public, indicating that the Authorized Signatory signing the agreement have the authority to sign the agreement and that the agreement is binding upon the service provider.**

21. भारत सरकार द्वारा लगाए गए प्रतिबंध:

भारत के साथ भूमि सीमा साझा करने वाले देश का कोई भी बोलीदाता इस निविदा में बोली लगाने के लिए तभी पात्र होगा जब बोलीदाता वित्त मंत्रालय, भारत सरकार के आदेश संख्या एफ संख्या 6 के अनुबंध- I में निर्दिष्ट सक्षम प्राधिकारी के साथ पंजीकृत हो। /18/2019-पीपीडी दिनांक 23.07.2020 और इस संबंध में विभिन्न संशोधन/स्पष्टीकरण जारी किए गए। सक्षम प्राधिकारी आदि से पंजीकरण के लिए अनुपालन और इसकी प्रक्रिया के उद्देश्य से बोलीदाताओं को उपर्युक्त आदेश के अनुपालन के संबंध में **अनुबंध-एच** (संलग्न) के अनुसार उपक्रम प्रस्तुत करना होगा। यदि बोली लगाने वाले द्वारा दिया गया वचन पत्र, जिसकी निविदा नियोक्ता द्वारा स्वीकार कर ली गई है, बाद के चरण में गलत पाया जाता है, तो यह तत्काल समाप्ति का आधार होगा और कानून के अनुसार आगे की कानूनी कार्रवाई की जाएगी।

20. SIGNING OF THE CONTRACT AGREEMENT.

- ▶ **The contract agreement shall be signed at NJHPS, SJVN, Jhakri (INDIA) in the office of undersigned within 15 days from the date of issue of LOA.**
- ▶ The Contract Agreement (s) will be signed in two (02) originals on non –judicial Stamp Paper (02 Nos) of ₹ 100/- each along with two (02Nos) copies of judicial paper of ₹ 1/-each within fifteen (15) days from the issue of Notification of awards/letter of Awards ***The non-judicial stamp papers & judicial papers are to be purchased from Himachal Pradesh only.***
- ▶ The agreement shall be signed by the authorized signatory of service provider/contractor , **While signing of agreement, satisfactory evidence of authority of the Authorized Signatory signing on behalf of the service provider shall be furnished on non-judicial stamp paper of an appropriate value in the**

Registered & Corporate Office	SJVN Corporate Head Quarter, Shanan, Shimla, Himachal Pradesh Pin No.-171006	Expediting Office	SJVN Limited, Office Block, Tower-1, 6 th floor, NBCC Complex, East Kidwai Nagar, New Delhi-110023.
-------------------------------	--	-------------------	--

form of a Power of Attorney/Authorization Letter, duly notarized by a Notary Public, indicating that the Authorized Signatory signing the agreement have the authority to sign the agreement and that the agreement is binding upon the service provider.

21. RESTRICTIONS IMPOSED BY GOVT OF INDIA:

Any bidder from a country which shares a land border with India will be eligible to bid in this tender only if the bidder is registered with the Competent Authority specified in Annexure-I of Ministry of Finance, Government of India order no F. No. 6/18/2019-PPD dated 23.07.2020 and various amendment/clarification issued in this regard. The bidders for the purpose of compliance and its procedure for registration from Competent Authority etc. The bidder has to submit the undertaking as per **Annexure-H (enclosed)** regarding compliance of above-mentioned order. In case the undertaking given by the bidder whose tender has been accepted by the Employer is found false at the later stage, this would be a ground for immediate termination and further legal action shall be taken in accordance with law.

Registered & Corporate Office	SJVN Corporate Head Quarter, Shanan, Shimla, Himachal Pradesh Pin No.-171006	Expediting Office	SJVN Limited, Office Block, Tower-1, 6 th floor, NBCC Complex, East Kidwai Nagar, New Delhi- 110023.
----------------------------------	---	----------------------	---

INFORMATION & INSTRUCTIONS FOR BIDDER -PCD-2961(Civil)2026

1.0 SUBMISSION AND FILLING OF BIDS:

1.1 **Please note that bids in physical form shall not be entertained under any circumstances and are only to be submitted through e-tendering at <https://etender.sjvn.co.in>.**

1.2 **DIGITAL SIGNATURES:** To participate in an e-Tender, bidder need to have a valid Class-3 Digital Certificate (Signing & Encryption/Combo) from certifying authority of India as per the IT Act, 2000. Valid Digital Certificate must be installed in a computer system from where you want to login on website. Perform the below steps to confirm whether valid digital certificate is available on your computer system or not. Perform the below steps to confirm whether valid digital certificate is available on your computer system or not.

Steps:

- Open Internet Explorer.
- Select Tools menu from menu bar. OR (Press Alt + T on your keyboard).
- Click on Internet Options >>Content >>Certificate button.
The bidder should view your digital certificate under “Personal” heading

Requirement of Digital Signature Certificate

- Please enable **ActiveX Controls & Plug-ins. (Tools->Internet Options-> Security- >Custom Level)**

Active-X controls need to be enabled in your Internet browser. In order to ensure this, please do the following:

- a. In Menu Bar ---Click on Tools - Internet Options – Security – Click on Trusted Sites Icon – Click on Sites button.
Add 2 Website in Trusted Sites <https://etender.sjvn.co.in>**

After that, click on

Tools menu of Internet explorer - Internet Options – Security – Click on Internet Icon.

After Click on Custom Level button –

From below ActiveX controls and plug-ins ---- Select below 5 Items to be enabled

1) Download signed ActiveX controls –select Prompt or Enable

2) Download unsigned ActiveX controls – select Prompt or Enable

- 3) Initialize and script ActiveX controls not marked as safe for scripting – select Prompt or Enable
- 4) Run ActiveX controls and plug-ins-select Enable
- 5) Script ActiveX controls marked safe for scripting – select Enable

After completed this above selection----Below option has available---**Reset custom settings---Reset To: Select low or medium ---Click on OK.**

Also, please check your system Date & Time it should be set as current date & time.

- Please disable or uninstall Third Party Toolbar / Add-ons from Browser.

1.3 **VENDOR REGISTRATION PROCESS:** After obtaining digital signature as indicated above, the bidder is to register with SJVN e- tendering portal <https://etender.sjvn.co.in> to participate in the tendering process. Perform below mentioned steps to register yourself:

- Click on a “New Bidder Registration” link available on home page
- You need to furnish individual details as well as of company details in registration form
- After filling all mandatory fields, you need to click on “submit” button to complete registration process.
- On successful completion of registration, you will be prompted a message saying that “You have successfully registered on SJVN Limited’s e-tender Portal”

Already valid registered vendors in SJVN systems with Vendor Id need not follow registration process and may contact support email:

1.4 **Down loading Bid Documents:** Bidder to access <https://etender.sjvn.co.in> to download NIT document, after completing registration formality (if required) and successful login vendor need to process for Tender Fee/ Document Fee as per the provisions of bid documents and thereafter bidder can download detailed tender document.

1.5 **Bid Submission:**

- I. Bidder needs to login on SJVN tendering portal i.e. <https://etender.sjvn.co.in>
- II. Search tender by filling necessary searching criteria after Login.
- III. Please refer to attached document of “Bidder User manual”.

All the bidders are requested to get themselves registered well in advance and no extra time will be considered for submission of bids for the delay in on-line Vendor Registration, if any.

Bidder(s) are also advised to keep on visiting the websites as mentioned below for any Notification/ Amendment / Addendum/ Corrigendum from SJVN's side in respect of this tender:

(i) <https://etender.sjvn.co.in>.

(ii) www.sjvn.nic.in.

(iii) www.eprocure.gov.in

1.6 **For any assistance/ clarification for e-tendering registration, submission of bid through e-tendering/ procurement, bidder may contact the following person: -**

1. **Sh. Ranjan Kumar: Mobile no. 85805-48817** (E-mail ID: etender.support@sjvn.nic.in)

For any other clarifications regarding the tender bidder may contact the following persons/ representatives of M/s SJVN:-

(i) Smt. Randeï Rana , ([E-mail ID: randei.rana@sjvn.nic.in](mailto:randei.rana@sjvn.nic.in))

(ii) Sh. Rajesh Kumar, ([E-mail ID: rajeshkr.negi@sjvn.nic.in](mailto:rajeshkr.negi@sjvn.nic.in)).

**Head of Dept. (HOD)
Procurement & Contract Deptt.
NJHPS, SJVN Ltd. Jhakri, Tehsil
Rampur Bsr., Distt Shimla (HP)-
172201.**

Bill of Quantity (BOQ) - PCD - 2961(Civil)2026

Name of Work: Painting Work on Ventilation Ducts of NJHPS Power House Complex, SJVN ltd. Jhakri .

Sr. No.	Description of Items	Unit	Qty.	Rates (Excl. GST)	Amount (Excl. GST)
1	Finishing with Epoxy paint (Two or more coats) at all locations prepared and applied as per manufacturer's specifications including appropriate priming coat, preparation of surface, etc. complete. On steel work.	Sqm	22014.05	185.93	₹ 4,093,072.00
	Total amount (without GST)				₹ 4,093,072

Bill of Quantity (BOQ) - PCD - 2961(Civil)2026

Name of Work: Painting Work on Ventilation Ducts of NJHPS Power House Complex, SJVN ltd. Jhakri .

Sr. No.	Description of Items	Unit	Qty.	Rates (Excl. GST)	Amount (Excl. GST)
1	Finishing with Epoxy paint (Two or more coats) at all locations prepared and applied as per manufacturer's specifications including appropriate priming coat, preparation of surface, etc. complete. On steel work.	Sqm	22014.05	185.93	₹ 4,093,072.00
	Total amount (without GST)				₹ 4,093,072

Special Terms and Conditions of Contract -PCD-2961(Civil)/2026

1. Time is the essence of the contract and no hindrance shall be considerable unless intimated by the contractor within 24 hrs. from its occurrence.
2. The clause at Sr. No. 15 of the Section-1 (Information's and Instructions for Tenderers) of the tender document may read as:

Earnest money (unless exempted @ **2%** of the estimated cost should be deposited by each tenderer in any one of the following forms payable at any schedule bank favouring. SJVN Ltd. Jhakri.

- a) Fixed deposit receipt issued by scheduled banks endorsed in favour of SJVN Ltd. Jhakri.
 - b) The Earnest Money Deposit at call shall not attract interest from the SJVN Limited.
 - c) EMD submitted by the contractor may be forfeited on the following grounds:-
 - i) On revocation of the tender or revision in rates after opening of the tender but before the validity of the quotation expires.
 - ii) On refusal to enter into a contract after the award of contract.
 - iii) If the work is not commenced after the work is awarded to a contractor
3. The clause at Sr. No. 16 of the Section-1 (Information and Instructions for Tenderers) of the tender document may read as:

The tenderer, whose tender is accepted (unless exempted) will be required to furnish security deposit for the due fulfilment of his contract.

The Security Deposit shall comprise the following:

- i. Performance Security Deposit to be furnished by the Contractor within 15 days from the date of issuance of Letter of award.
 - ii. Retention Money to be recovered from Interim bills of the Contractor.
- (a) The Contractor within 15 (Fifteen) days from the date of issuance of Letter of Award, shall furnish a **Performance security deposit of 3% (Three percent)** of the Contract Price for due performance of contract. The Performance Security Deposit shall be in the form of a FDR pledged to SJVN Ltd. issued by a Nationalized/ Scheduled Indian Bank located in India acceptable to SJVN Ltd.

Note:

- (i) The interest* shall be charged on delay period for breach in timely submission of Performance Security deposit without prejudice to right of SJVN to other remedies available under the contract. The GST shall be levied & recovered extra on interest as per applicable rule of GST.

****interest shall be chargeable on per day basis on the amount of CPG/PSD @ SBI MCLR as on date of bid submission specified in the tender document +200 basis points.***

- (ii) In case last day of submission of performance security deposit happens to be a bank holiday, the last day of submission shall be the next working day.
- (b) Retention money shall be deducted by the Engineer-in-Charge from the interim bills of the

Contractor @ 3% (three percent) of the total value of each bill of the work done towards security deposit.

- (c) The security deposit shall be valid for a period of six months beyond the date of issue of completion certificate. The security deposit shall not attract any interest from SJVN Limited.
 - (d) The Notification of Award/ Letter of Acceptance will constitute the formation of the Contract until formal agreement is signed and further subject only to the furnishing of a performance security deposit in accordance with the relevant provisions of Tender/ bid Document.
4. During continuance of the Contract, the Contractor and his sub-Contractors shall abide at all times by all existing labour enactments and rules made there under, regulations, notifications and bye laws of State or Central Government or local authority and any other labour law (including rules), regulations, bye laws that may be passed or notification that may be issued under any labour law in future either by the State or the Central Government or the local authority. The Contractor shall keep the Employer indemnified in case any action is taken against the Employer by the competent authority on account of contravention by the Contractor of any of the provisions of any Act or rules made there under, regulations or notifications including amendments. If the Employer is caused to pay or reimburse, such amounts as may be necessary to cause or observe, or for non-observance of the provisions stipulated in the notifications/bye laws/acts/rules/regulations including amendments, if any, on the part of the Contractor, the Engineer/Employer shall also have right to recover from the Contractor any sum required or estimated to be required for making good the loss or damage suffered by the Employer.

The employees of the Contractor and his sub-Contractor in no case shall be treated as the employees of the Employer at any point of time.

Some of the major labour laws that are applicable to construction industry are given below.

- (i) Workmen Compensation Act 1923 as amended by Amendment Act No.65 of 1976.
- (ii) Payment of Gratuity Act 1972
- (iii) Employees PF and Miscellaneous Provision Act 1952 including FPS- 71/EPS-95.
- (iv) Maternity Benefit Act 1961 (Amended)
- (v) Contract Labour (Regulation and Abolition) Act 1970 with Rules framed there under as amended.
- (vi) Minimum Wages Act 1948 (Amended)
- (vii) Payment of Wages Act 1936 (Amended)
- (viii) Equal Remuneration Act 1979
- (ix) Payment of Bonus Act 1965 and Amendment Act No.43 of 1977 and No.48 of 1978 and any amendments thereof.
- (x) Industrial Disputes Act 1947(Amended)
- (xi) Industrial Employment (Standing Orders) Act 1946 (Amended)
- (xii) Trade Unions Act 1926
- (xiii) Child Labour (Prohibition and Regulation) Act 1986
- (xiv) Inter-State Migrant Workmen's (Regulation of Employment and Conditions of Service) Act 1979
- (xv) The Building and Other Construction Workers (Regulation of Employment and Conditions of Service) Act 1996 and the Cess Act of 1996

(xvi) The Personal Injuries (Compensation Insurance) Act, 1963 and any modifications thereof and rules made there under from time to time.

- 5 Contractor will have to produce W-Form/X-form (as applicable) for material to be utilized (such as stone, aggregate, sand etc.) for construction work under H.P Mineral Rules, 2015 (Prevention of illegal Mining, Transportation and Storages).**
- 6 Recovery of serviceable stone**:- Serviceable stone shall be recovered minimum @ Rs. 1511/- Plus@18% GST of Rs. 271.98/- = Rs. 1783/- per cum (if applicable). If a tender is awarded higher than the estimated cost then the rate for recovery of stone (per cum) shall be increases in proportion.
- 7** It should be ensured that the following clauses of Indian Standard Code are complied with:
 - a)** Clause 26.1 of IS 456: 2000, which states that "Reinforcing steel of same type and grade shall be used as main reinforcement in a structural member. However, simultaneous use of two different types of grades of steel for main and secondary reinforcement respectively is permissible".
 - b)** Note given along with Clause 1.0 of SP-34 stating "Different types of reinforcing bars, such as plain bars and deformed bars of various grades, say Fe415 (N/mm²) and Fe50() (N/mm²), should not be used side by side as this practice will lead to confusion and error at site. However, secondary reinforcement such as ties and stirrups, may be of mild steel throughout even though the main steel may be of high strength deformed bars".
- 8** Owing to lower bond strength any grade of plain bars shall be avoided as reinforcement in RCC constructions.
- 9** Contractor should be instructed to plan the reinforcement steel requirements of various types grades sufficiently in advance and place his orders accordingly so that, appropriate types and grade are available at site when required and no such changes in grade or type are necessitated by non-availability of required reinforcement.
- 10** The type and grade of reinforcement steel should be specified clearly in design drawings. Appropriate notes should be given to avoid any ambiguity.
- 11** Quality control department at site should conduct checks to ensure that correct grade of reinforcement is being used at site. Regular audits should be conducted. Non-compliance, if any, observed by site quality control department, shall be reported immediately to concerned Corporate Deign department / Corporate Quality department.
- 12** Appropriate measures should be taken at site to ensure that different grades of steel are easily distinguished and do not get mixed up during, transportation, storage and placement.

**Head of Dept. (HOD),
Procurement & Contract Deptt.,
NJHPS Jhakri, Distt. Shimla (HP).**

Bid Security Declaration

Tender No: SJVN/NJHPS/P&C/PCD-2961 (Civil)/2026

Date:

To

Deputy General Manager,
Procurement and Contract Deptt.
NJHPS, SJVN Ltd. Jhakri,
Distt. Shimla-H.P.-172201.

I hereby submit a declaration that the bid submitted by the undersigned, on behalf of the bidder _____(Name of the bidder) shall not be withdrawn or varied during the period of bid validity as stipulated in Tender Document.

I, on behalf of the bidder _____(Name of the Bidder), also accept the fact that in case the bid is withdrawn or varied any term & condition in regard hereto during the period of bid validity , except as provided in Tender Document or in the case of a successful bidder ,if we fail within the specific time limit to sign the agreement or we fail to furnish the required performance security as provided in **Clause 3 of Annexure C (Additional Special Terms & Conditions)** of Tender Document or if we adopt the corrupt or coercive or fraudulent practices covered under **Clause 12 of NIT** of Tender Document, then _____ (Name of Bidder) will be suspended for participation in the tendering process for the work of SJVN Ltd. and its subsidiaries and work under other centrally sponsored schemes, for a period of one year from the date of issue of notice of such suspension by the Employer.

Date: _____ (Signature of Authorised Signatory)*
Place: _____ (Name).....
_____ (Designation).....
_____ (Common Seal).....

****In case of a Sole Bidder, Bid Security Declaration should be on the letterhead of the Bidder/firm and should be signed by a person competent and having the Power of Attorney to bind the Bidder.***

Registered & Corporate Office	SJVN Corporate Head Quarter, Shanan, Shimla, Himachal Pradesh Pin No.-171006	Expediting Office	SJVN Limited, Office Block, Tower-1, 6 th floor, NBCC Complex, East Kidwai Nagar, New Delhi-110023.
-------------------------------	--	-------------------	--

Undertaking

I/We, M/s.....(Name of Bidder) hereby certify that I/We would adhere to the fraud prevention and detection policy of SJVN and not indulge myself/ourselves or allow anybody else working in our organization to indulge in fraudulent activities and would immediately apprise the SJVN authorities regarding the fraud/suspected fraud as soon as it comes to my/our notice.

Date:

For and on behalf of the bidder

.....

Registered & Corporate Office	SJVN Corporate Head Quarter, Shanan, Shimla, Himachal Pradesh Pin No.-171006	Expediting Office	SJVN Limited, Office Block, Tower-1, 6 th floor, NBCC Complex, East Kidwai Nagar, New Delhi-110023.
-------------------------------	--	-------------------	--

(Format for Undertaking of Self certification regarding Local Content In line with PPP-M II order, 2017 & Revision PPP-M II order, 2017 dated 16/09/2020, 28/07/2020 & if applicable, to be provided on a **company letterhead by authorized person**)

Tender of Description: “PCD-2961(Civil)/2026- “Painting Work on Ventilation Ducts of NJHPS Power House Complex”

• Bidder's Name and Address (Bidder) :
Name:

To:
Procurement and Contract Deptt.
NJHPS, SJVN Ltd. Jhakri
Distt. Shimla HP 172201

Dear Sir,

Format for Self-certification regarding Local Content in line with PPP-M II order, 2017 and Revision PPP-M II 2017 date 04/06/2020 & 28/07/2020 if applicable, to be provided on company letterhead by the authorized person.

Date: -

I _____ S/o,D/o,W/o _____
Resident of _____ here by solemnly affirm and declare as under:-

That I will agree to abide by the terms and conditions of the Public Procurement (Preference to Make in India) Order, 2017 (hereinafter PPP-M II order) of Government of India issued vide Notification No:P-45021/2/2017-BE-II dated 15/06/2017, its revision dated 04/06/2020, Notification No. P-45021/2/2017-PP(BE-II)-part(4) Vol.II date 19/07/2024 & in MOP Letter Public procurement (Preference to make in India) to provide for purchase preference (linked with local content) in respect of Hydro Power Sector Order 28/07/2020, and any subsequent modifications/ Amendments, if any the information furnished hereinafter is correct to the best of my knowledge and belief and I undertake to produce relevant records before the procuring entity/ SJVN Ltd or any other Government authority for the purpose of assessing the local content of goods/services/works supplied by me for **(Enter the name of the Tender)**.

That the local content for all inputs which constitute the said goods/ services/works has been verified by me and I am responsible for the correctness of the claims made therein. That the goods/ services/works supplied by me for ----- **(Enter the name of the Tender)** meet the 'Minimum Local Content' as defined in the PPP-M II order and MoP order 28/07/20 and value of local content (in..... %).

That the value addition for the purpose of meeting the 'Local Content 'has been made by me at **{Enter the details of the location(s) at which value addition is made}** .

We ensured that the imported items sourced locally from resellers/distributors are excluded from the calculation of local content. Details of the cost of locally sourced imported items (inclusive of taxes) along with the breakup on license/royalties paid/technical expertise cost etc. sourced from outside India are as under:-

Registered & Corporate Office	SJVN Corporate Head Quarter, Shanan, Shimla, Himachal Pradesh Pin No.-171006	Expediting Office	SJVN Limited, Office Block, Tower-1, 6 th floor, NBCC Complex, East Kidwai Nagar, New Delhi-110023.
-------------------------------	--	-------------------	--

i.	Cost	of
locally sourced imported items (inclusive of taxes) in Rs		
ii.	Cost	of
license/royalties paid outside India in Rs		
iii.	Cost	of
technical expertise cost etc. sourced from outside India in Rs		

That in the event of the local content of the goods/ services/works mentioned herein is found to be incorrect and not meeting the prescribed Local Content criteria, based on the assessment of procuring agency (ies)/ SJVN Ltd/Government Authorities for the purpose of assessing the local content, action shall be taken against me in line with the Revision PPP-MII order dated 04/06/2020 and MOP order dated 28/07/2020 and provisions of the Bidding Documents.

I agree to maintain the following information in the Company's record and shall make this available for verification to any statutory authority. **Further, Self-declarations/ auditor's/ account's certificates submitted by the manufacturer/ supplier may be verified randomly by the committee constituted as per MoP order 28-07.2020. In case of false documents/misrepresentation of the facts requisite action against such manufacturer/supplier will be taken based on the recommendation of the Committee."**

i Name and details of the Local Supplier

(Registered Office, Manufacturing unit location, nature of legal entity)

ii. Date on which this certificate is issued

ii. Goods/services/works for which the certificate is produced

For and on behalf of.....(Name of firm/entity).

Authorized signatory (To be duly authorized by the Board of Directors)

Name:-

Designation:-

Contact No.

Date :

Registered & Corporate Office	SJVN Corporate Head Quarter, Shanan, Shimla, Himachal Pradesh Pin No.-171006	Expediting Office	SJVN Limited, Office Block, Tower-1, 6 th floor, NBCC Complex, East Kidwai Nagar, New Delhi-110023.
-------------------------------	--	-------------------	--

Undertaking

I/Wehereby undertake/certify as under:-

1. That I/We have read all the documents uploaded along with the NIT and there are no deviations from the standard terms and conditions of the tender document & NIT etc.
2. That the documents as uploaded by me/us are as per original document.

Date:

For and on behalf of the bidder

Registered & Corporate Office	SJVN Corporate Head Quarter, Shanan, Shimla, Himachal Pradesh Pin No.-171006	Expediting Office	SJVN Limited, Office Block, Tower-1, 6 th floor, NBCC Complex, East Kidwai Nagar, New Delhi-110023.
-------------------------------	--	-------------------	--

UNDERTAKING (PCD-2961(civil)/2026)

(In compliance of Ministry of Finance, Government of India order no F. No. 6/18/2019-PPD dated 23.07.2020)

I have read the clause regarding restrictions on procurement from a bidder of a country which shares a land border with India.

I certify that(name of Bidder) is not from such a country or, if from such a country, has been registered with the Competent Authority. I hereby certify that(name of Bidder) fulfills all requirements in this regard and is eligible to be considered.

Note:- Evidence of valid registration by the Competent Authority shall be attached (if applicable)

Place:

Date:

(Signature)

Registered & Corporate Office	SJVN Corporate Head Quarter, Shanan, Shimla, Himachal Pradesh Pin No.-171006	Expediting Office	SJVN Limited, Office Block, Tower-1, 6 th floor, NBCC Complex, East Kidwai Nagar, New Delhi-110023.
-------------------------------	--	-------------------	--

PCD-2961(Civil)/2026

Annexure -“I”.

- 1) The contractor should be asked to apply for photo gate pass to all the labourers who are engaging for work with their full residential address as per Form-B.
- 2) The Character and Antecedents of all the labours are required to be verified through their respective local Police as per address in AADHAR Card, 10 days before start of work.
- 3) The Labour of Nepal, Bangladesh, J &K and Tibet origin are required to be registered in the local Police stations before engaging by the contractor for work and their finger impression and photographs are required to be recorded in the local Police Station.
- 4) The Labour will not use a Dangri, Army / Police force uniform colour while Work in the project site(s).

Registered & Corporate Office	SJVN Corporate Head Quarter, Shanan, Shimla, Himachal Pradesh Pin No.-171006	Expediting Office	SJVN Limited, Office Block, Tower-1, 6 th floor, NBCC Complex, East Kidwai Nagar, New Delhi-110023.
-------------------------------	--	-------------------	--

Guidelines on Banning of Business Dealings {PCD-2961}(CIVIL/2026}

Guidelines on Debarment of Business Dealings for SJVN Limited (including its Subsidiaries and Joint Ventures)

1.0 Introduction

SJVN (including its subsidiaries, and joint ventures) deal with various bidders, contractors, suppliers, consultants, and service providers, who are expected to adopt ethics of highest standards and a very high degree of integrity, commitments and sincerity towards the work undertaken. It is not in the interest of SJVN to deal with Agencies who commit deception, fraud or other misconduct in the tendering process.

These Guidelines are issued with a view to ensuring transparency, integrity, and fairness in public procurement undertaken by **SJVN Limited**, its Subsidiaries and Joint ventures.

These guidelines are framed in alignment with the 'Guidelines on Debarment of firms from Bidding' issued by the **Department of Expenditure, Ministry of Finance, Government of India**.

2.0 Scope

These Guidelines shall apply to all procurements financed, executed, or managed by SJVN, its Projects, Power Stations, Regional Offices, Liaison Offices including its subsidiaries, and joint ventures, and shall be binding upon all categories of bidders, contractors, suppliers, consultants, and service providers dealing with SJVN or its associated entities.

3.0 Definitions

- a) **SJVN** means SJVN Ltd., its Projects, Power Stations, Regional Offices, Liaison Offices including its subsidiaries, and joint ventures.
- b) **Debarment** means disqualification of a bidder from participation in any procurement process undertaken by SJVN for a specified period in accordance with Rule 151 of GFR 2017.

For the purposes of these Guidelines, the expressions *banning of firm*, *suspension*, and *blacklisting* shall convey the same meaning as *debarment*.

- c) **Firm:** The term 'Firm' or 'Bidder' has the same meaning for the purpose of these guidelines, which includes an individual or person, a company, a co-operative society, a Hindu undivided family, and any association or body of persons, whether incorporated or not, engaged in trade or business.
- d) **Allied Firm** means any concern within the sphere of effective influence of a debarred firm. In determining such influence, the following factors shall be considered—
 - (i) whether the management is common;
 - (ii) whether majority interest in the management is held by the partners or directors of the debarred firm;
 - (iii) whether substantial or majority shares are owned by the debarred firm and, by virtue thereof, it has a controlling voice;

Registered & Corporate Office	SJVN Corporate Head Quarter, Shanan, Shimla, Himachal Pradesh Pin No.-171006	Expediting Office	SJVN Limited, Office Block, Tower-1, 6 th floor, NBCC Complex, East Kidwai Nagar, New Delhi-110023.
-------------------------------	--	-------------------	--

- (iv) whether the firm directly or indirectly controls, or is controlled by, or is under common control with another bidder; and
- (v) all successor firms shall also be treated as allied firms.

e) **Unit** shall mean the Project/ Power Station/ Regional Office/ Liaison Office/Subsidiary/JV, as the context requires.

4.0 Authorities and Jurisdiction

(a) SJVN-level Debarment.

Competent Authority: Functional Director, SJVN. In case of subsidiaries, the Competent Authority shall be CEO.

Appellate Authority: Chairman & Managing Director (CMD), SJVN. In case of subsidiaries, the Appellate Authority shall be Chairman of the subsidiary.

(b) Ministry of Power (MoP)-level Debarment.

Debarment orders issued or endorsed by the Ministry of Power shall be governed by the Competent and Appellate Authorities as may be notified by the Ministry from time to time, and shall be binding on SJVN, its subsidiaries, and joint ventures for the period specified therein.

(c) Department of Expenditure (DoE)-level Debarment.

Debarment orders issued or endorsed by the Department of Expenditure, Ministry of Finance, Government of India, shall be governed by the Competent and Appellate Authorities specified by the said Department, and shall be binding on SJVN, its subsidiaries, and joint ventures for the period specified therein

5.0 Initiation of Debarment proceedings

During bidding: Action for banning of business dealings with any Firm shall be initiated by the department responsible for invitation of bids after noticing the irregularities or misconduct on the part of Firm concerned.

During execution: Action for banning of business dealings with any Firm shall be initiated by the respective department responsible for execution of works/services after noticing the irregularities or misconduct on the part of Firm concerned.

Besides the concerned department, Vigilance Department of each Unit/ Corporate Vigilance may also be competent to initiate such action.

6.0 Grounds for Debarment

Without prejudice to Rule 151 and Rule 175 of GFR 2017, a bidder or any of its successors may be debarred from participation in procurement undertaken by SJVN and its subsidiaries and JVs for any of the following reasons—

- a) conviction under the *Prevention of Corruption Act, 1988*, the *Indian Penal Code* or *Bhartiya Nyaya Sanhita, 2023*, or any other law in force, for causing loss of life, damage to property, or threat to public health in the course of execution of a public procurement contract;
- b) breach of the *Code of integrity* prescribed under Rule 175 of GFR 2017, including bribery, collusion, bid-rigging, anti-competitive conduct, false declaration, obstruction of investigation or audit, or undisclosed conflict of interest;
- c) submission of false or forged information, misrepresentation, or concealment of material facts, resorting to corrupt or fraudulent practices;
- d) persistent failure, default, or non-performance of contractual obligations;
- e) supply of substandard material, non-supply of material, abandonment of works, sub-standard quality of works, or failure to abide by the Bid Securing Declaration etc.;
- f) misuse of SJVN's premises or its facilities, forcefully occupies or damages SJVN's properties

Registered & Corporate Office	SJVN Corporate Head Quarter, Shanan, Shimla, Himachal Pradesh Pin No.-171006	Expediting Office	SJVN Limited, Office Block, Tower-1, 6 th floor, NBCC Complex, East Kidwai Nagar, New Delhi-110023.
-------------------------------	--	-------------------	--

- including land, water resources, forests / trees or tampers with documents/records etc.; and
- g) Any other act or omission which, in the opinion of SJVN, warrants debarment in the interest of probity, fairness, and public interest.

7.0 Debarment Review Committee (DRC) and Procedure for Debarment

a) Constitution of DRC:

Prior to the initiation of debarment proceedings, the Competent Authority shall constitute a Debarment Review Committee (DRC) for examination of the case. The Committee shall comprise officers not below the rank of General Manager or Head of Department / Head of Project, as under—

- One officer from Contracts or Procurement of the concerned Unit or the Corporate Office;
- One officer from Finance (Corporate / Projects) of the concerned Unit or Corporate Finance;
- One officer from Corporate Law / Legal; and
- One officer representing the user or indenting department at the Corporate or Unit level, or the Head of Project / Engineer-in-Charge representing the concerned project site, as the case may be.

The officer belonging to the department initiating the proposal for debarment shall act as the Coordinator of the DRC and shall be responsible for convening meetings, facilitating examination of relevant records etc. The DRC shall submit its report to the Competent Authority.

b) Mandate and Process:

The DRC shall,

- (i) examine all facts, records, and evidence pertaining to the case;
- (ii) ensure that a show-cause notice has been issued and that a reasonable opportunity of representation, including personal hearing if sought, has been afforded;
- (iii) assess the applicability to allied and successor firms; and
- (iv) submit a reasoned and self-contained recommendation to the Competent Authority within eight (08) weeks, extendable with recorded justification.

c) Decision:

The DRC shall function in an advisory capacity. The final decision shall rest with the Competent Authority, who shall, after due consideration of the DRC's recommendation, issue a *speaking order* specifying the reason (in brief), scope, jurisdiction, and duration of debarment.

The entire proceeding shall, as far as practicable, be concluded within twelve (12) weeks from the date of initiation.

8.0 Period and Effect of Debarment

- a) Maximum period — up to three (3) years for conviction-based cases under Rule 151(i) (DoE-wide), and up to two (2) years for breach of the Code of Integrity or performance-related grounds at the SJVN/MoP level.
- b) Minimum period —ordinarily not less than six (6) months.
- c) Commencement — the period of debarment shall commence from the date of issue of the debarment order by the issuing entity.
- d) Contract Placement Bar — no contract of any kind shall be placed on a debarred firm, including its allied firms; this prohibition shall also apply in cases of risk purchase.

Registered & Corporate Office	SJVN Corporate Head Quarter, Shanan, Shimla, Himachal Pradesh Pin No.-171006	Expediting Office	SJVN Limited, Office Block, Tower-1, 6 th floor, NBCC Complex, East Kidwai Nagar, New Delhi-110023.
-------------------------------	--	-------------------	--

- e) Bid/Contract Dates — only bids from firms that are not debarred on (i) the date of submission/opening of the tender and (ii) the date of issuance of Letter of Award/ Signing of Contract Agreement shall be considered.
- f) Bids by Debarred Firms — if a debarred firm submits a bid, such bid shall be ignored. If such firm is the lowest (L-1), the next lowest eligible bidder shall be considered as L-1. Any bid security submitted by the debarred firm shall be returned.
- g) Existing Contracts —contracts concluded prior to the issue of the debarment order shall not be affected.
- h) Removal from approved/empanelled lists — the debarred firm shall also be removed from any approved/empanelled lists.

9.0 Applicability to Allied and Successor Firms

Debarment of a firm shall automatically extend to its allied and successor firms unless otherwise directed by the Competent Authority for reasons recorded in writing.

In the case of debarment of a joint venture or consortium, all partners shall stand debarred for the period specified in the debarment order, and the names of all such partners shall be explicitly mentioned in the order.

10.0 Jurisdiction and Recommendation of Debarment

- a) **SJVN-Level Debarment:** for misconduct confined to SJVN or its subsidiaries/joint ventures, including non-performance, false declarations, or breach of integrity obligations.
- b) **Recommendation to Ministry of Power (MoP):** for cases having sector-wide or systemic implications affecting multiple PSUs under the administrative control of MoP, or integrity breaches such as corruption, bribery, or cartelization in tenders of SJVN.
- c) **Recommendation to Department of Expenditure (DoE):** for conviction-based cases or offences causing loss of life, property, or threat to public health, warranting Government-wide debarment under Rule 151.

Where such Government-wide debarment is warranted, the department responsible for initiation of debarment proceedings shall forward a self-contained proposal, along with complete supporting documentation, to the Ministry of Power for onward transmission to the Department of Expenditure, in accordance with the DoE OM.

11.0 Effect of Debarment by Other Authorities

SJVN shall give effect to debarment orders issued by the **Department of Expenditure (Ministry of Finance)**, the **Ministry of Power**, or any other Government entity, where such orders expressly provide for applicability across Ministries, Departments, or PSUs.

Note (GeM). The Government e-Marketplace (GeM) may debar bidders for a period of up to two (2) years on its portal. SJVN shall honor such debarments for procurements undertaken on or through GeM, in accordance with GeM provisions.

Registered & Corporate Office	SJVN Corporate Head Quarter, Shanan, Shimla, Himachal Pradesh Pin No.-171006	Expediting Office	SJVN Limited, Office Block, Tower-1, 6 th floor, NBCC Complex, East Kidwai Nagar, New Delhi-110023.
-------------------------------	--	-------------------	--

12.0 Publication of Debarment Orders

Debarment orders issued by SJVN shall be displayed on SJVN's website and shall be binding upon all subsidiaries and joint ventures of SJVN. For the purpose, the concerned department shall forward the name and details of the Agency (ies) banned to IT&C Division of SJVN's Corporate Office for displaying the same on SJVN website. The details shall also be displayed on the respective subsidiary's website.

Debarment orders of the Ministry of Power shall be displayed on the Ministry's website, and those of the Department of Expenditure shall be displayed on the *Central Public Procurement Portal (CPPP)* maintained by DoE.

13.0 Appeal and Review (SJVN Level)

An aggrieved firm may prefer an appeal to the CMD, SJVN, within thirty (30) days from the date of communication of the SJVN-level debarment order.

The CMD may, after due consideration of the record and representation, uphold, modify, or set aside the order.

Appeal against MoP/DoE orders shall be dealt as per Guidelines on Debarment of firms from Bidding' issued by the **Department of Expenditure, Ministry of Finance, Government of India**.

14.0 Revocation and Reinstatement

- (a) A debarment order shall stand automatically revoked upon expiry of the period specified therein; no separate order shall be required.
- (b) For debarments issued by SJVN, the CMD, SJVN shall be the sole authority competent to review or revoke the order prior to its expiry, either *suo motu* or upon representation by the firm, based on new facts or sufficient justification.

Such revocation shall be issued by formal order and shall take effect from the date specified therein.

- (c) For debarments issued by the Ministry of Power or the Department of Expenditure, revocation or modification prior to expiry shall rest exclusively with the respective issuing authority.
- (d) Upon receipt of a revocation or modification order, the concerned department shall promptly update internal records and, where applicable, SJVN's website or the CPPP.

Note: In case of shortage of suppliers/contractors/service providers in a particular group, such debarments may also hurt the interest of procuring entities. In such cases, endeavour should be to pragmatically analyse the circumstances, try to reform the supplier and may get a written commitment from the suppliers / contractors / service providers that its performance will improve.

15.0 Record-Keeping and Reporting

All proceedings, communications, and decisions under these Guidelines shall be duly forwarded for record to Corporate Civil Contracts Deptt.

A consolidated list of firms debarred and reinstated at the SJVN level shall be maintained by Corporate Contracts Deptt. and published on SJVN's website.

Matters having inter-ministerial or sectoral implications, including those requiring consideration by the Department of Expenditure, Ministry of Finance, shall be reported to the **Ministry of Power** through the **Corporate Civil Contracts Department**, in accordance with the procedure prescribed under the DoE OM.

Registered & Corporate Office	SJVN Corporate Head Quarter, Shanan, Shimla, Himachal Pradesh Pin No.-171006	Expediting Office	SJVN Limited, Office Block, Tower-1, 6 th floor, NBCC Complex, East Kidwai Nagar, New Delhi-110023.
-------------------------------	--	-------------------	--

**Form of Declaration of Eligibility
Undertaking**

I/We,[Name of the Bidder / Firm / Company],
having our registered office at [.....], do hereby certify that
neither I/we nor any of our allied firms, successor entities, consortium / joint-venture partners (as
applicable) are currently under debarment by SJVN Limited (including its subsidiaries/JVs), the
Ministry of Power, Government of India, or the Department of Expenditure (DoE), Ministry of
Finance, Government of India.

I/We fully understand that if this declaration/undertaking is found to be false or misleading, our Bid
shall be liable for rejection and, if the Contract has been awarded, the same shall be liable for
termination, in addition to any other action as may be taken under law.

Date.

Place.....

(Name & Signature of Authorised Representative
With Seal/Stamp of Company)

Registered & Corporate Office	SJVN Corporate Head Quarter, Shanan, Shimla, Himachal Pradesh Pin No.-171006	Expediting Office	SJVN Limited, Office Block, Tower-1, 6 th floor, NBCC Complex, East Kidwai Nagar, New Delhi-110023.
----------------------------------	---	----------------------	---

DELETION OF CLAUSES -PCD-2961(Civil)/2026

The following clauses mentioned in the Tender Document may be read as deleted.

(i) Section –III

Clause No. 10 C.

Clause No. 30

Clause No. 43.

Clause No. 44

(ii) Section-IV

विभागाध्यक्ष

प्रापण एवं संविदा विभाग,

एस0जे0वी0एन0,लि0 झाकडी।

Registered & Corporate Office	SJVN Corporate Head Quarter, Shanan, Shimla, Himachal Pradesh Pin No.-171006	Expediting Office	SJVN Limited, Office Block, Tower-1, 6 th floor, NBCC Complex, East Kidwai Nagar, New Delhi-110023.
-------------------------------	--	-------------------	--

Registration details of Corporate Office, Shimla (Principle Place of Business)

Sr. No.	Data Particular	Data
1	Supplier/ Reccipient name	SJVN Limited
2	Type of supplier/ Reccipient (for B2B Suppliers)	Registered/ unregistered, Composite/ Foreign/ Casual/ Consumer (Strike out which is not applicable)
3	ARN No.	AA020317004466N
	Prov. GSTIN/GSTIN (for B2B Suppliers)	02AAICS1307F1ZY
4	Address of registered place of Business of the Suppliers under GST along with State code and PIN code (for B2B Suppliers) which is also the location of the business of SJVN Ltd.	SJVN Ltd., Corporate Office Complex, Shakti Sadan, Shanan, Shimla (HP)- 171006 State Code-02
5	PAN	AAICS1307F
6	TAN	PTLS13839A
7	UID No. in case of Embassy/UN	Not applicable
8	Status of suppliers i.e. whether SEZ, EOU, DTA, Government, Local Authority	Not Applicable
9	Name & Designation of Contact Person	Sh. S.K.Sood, Chief General Manager (F&A)
10	Email Address	corporate_finance@sjvn.nic.in
11	Mobile No.	94184-68573
12	Phone No.	0177-2660232

Name of work : "Painting Work on Ventilation Ducts of NJHPS Power House Complex" (PCD-2961)(civil)/2026	Schedule-1
---	------------

SJVN Ltd.

NJHP Station (1500 MW)

"General Information & Bank Account Detail"

Techno-commercial bid part

The Following is the general information regarding Contact Person, Contact Detail and Phone/ Fax Nos. and Bank Account Detail for "Painting Work on Ventilation Ducts of NJHPS Power House Complex" PCD-2961(Civil)/2026" - if the order is awarded then the payment is to be released through RTGS as per the following detail:

Sl. No.	Description	Detail
1	Bidder's Name & Complete Address With Postal Code	
2	Bid reference No.	
3	Contact Persons	
	Date of Birth of Contact Person	
4	Contact Numbers	
5	Fax No.	
6	Website if any	
7	e-mail id	
8	Bank Account Details (For release of payment / EMD through NEFT/RTGS)	
(i)	Name of the Beneficiary (Exactly same as mentioned in the Bank Account)	
(ii)	Name of the Bank	
(iii)	Name of Branch	
(iv)	IFSC Code No.	
(v)	Bank Account Number	
9	PAN No.	
10	GST No.	
11	Registration No.	
12	EPF No.	
13	whether Micro/small Enterprises	
14	Whether Micro/small Enterprises owned by SC/ST/Woman	
15	Type of Category of Micro/ small Enterprises (General/ SC/ST)	
Date :		
Place :		

SJVN Limited

(6X250MW Nathpa Jhakri Hydro Power Station)

Name of Work: "Painting Work on Ventilation Ducts of NJHPS Power House Complex" PCD-2961(Civil)/2026"

Bidder's Name & Address :

To

Head of dept. (HOD)

Procurement & Contract Deptt.

NJHPS, SJVN Ltd. , Jhakri.

Sr.No.	Description of document	Reference No. / Certificate No.	Relevant detail.
1	Financial Turnover as per NIT		
(a)	F.Y. - 2022-23		
(b)	F.Y.- 2023-24		
(c)	F.Y. - 2024-25		
2	Work Experience as per NIT.		
(a)			
(b)			
(c)			